

Three-Hinged Arches

- Arches on even supports
- Arches on uneven supports

Salginatobel Bridge
Switzerland, 1930
Robert Maillart



Three Hinged Arches

Salginatobel Bridge
Schiers, Switzerland, 1930
Robert Maillart

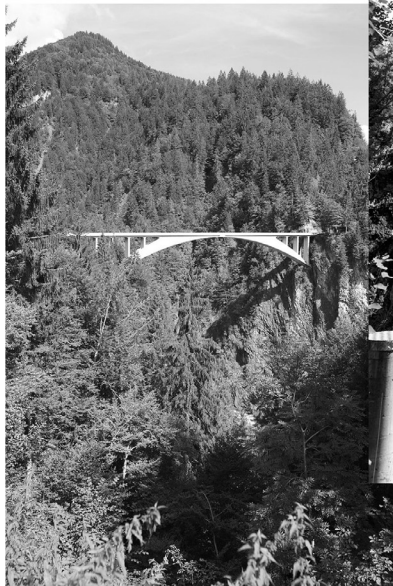

Arch Reactions

Unlike a beam, where reactions are principally vertical, reactions of an arch need to resist **horizontal thrust** as well.

If a reaction is “**pinned**” only two forces are needed to describe it. When both reactions are pinned, there are a total of 4 unknowns, and the structure is **indeterminate to the 1st degree**.

If a reaction is “**fixed**”, three forces are needed to describe it. When both reactions are fixed, there are a total of six unknown components, and the structure is **indeterminate to the 3rd degree**.

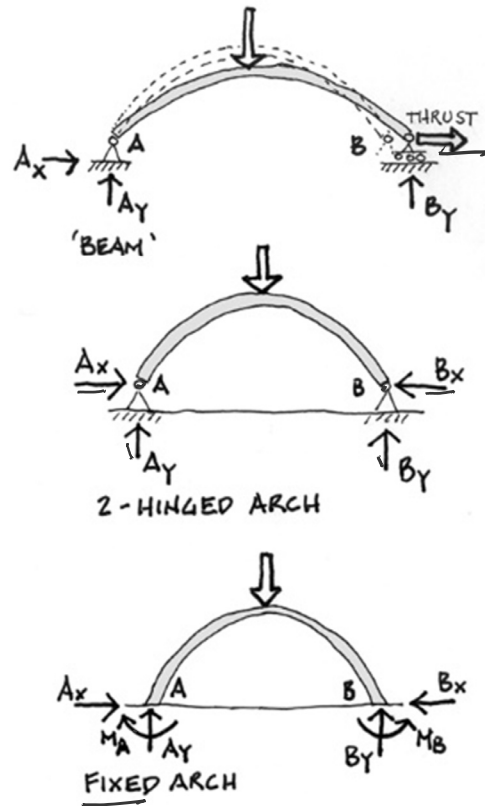

3-Hinged Arch

The 3-Hinged Arch has a “hinge” at each pinned support **plus one more internally**. The internal hinge provides one additional statics equation to be written since the moment at C is known ($M_C = 0$). This makes the system **statically determinate**.

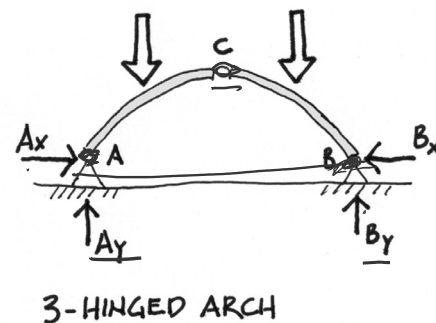

The solution of the end reactions can usually be obtained in **two steps**.

1. finding the **vertical reactions** by using the diagram of the whole structure
2. summing moments at the internal hinge on an FBD of half of the structure to find the **horizontal forces**

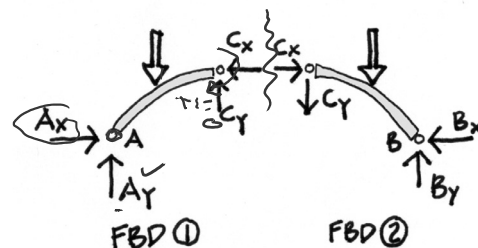

Characteristics of a 3-Hinged Arch

- Statically determinate – can be calculated with statics
- Movement or settling of foundations will not alter member stresses
- Small fabrication errors in length do not affect internal stresses
- Hinge placement can reduce internal stresses

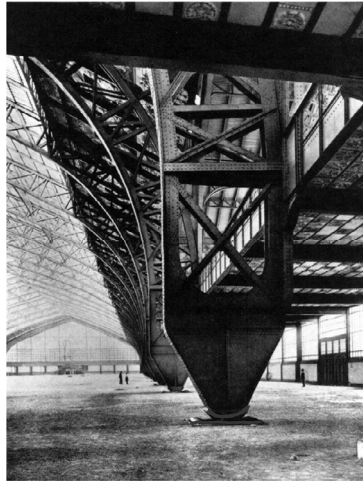

Gallery of the Machines, 1889 Paris
 Architect: Ferdinand Dutert
 Engineer: Victor Contamin

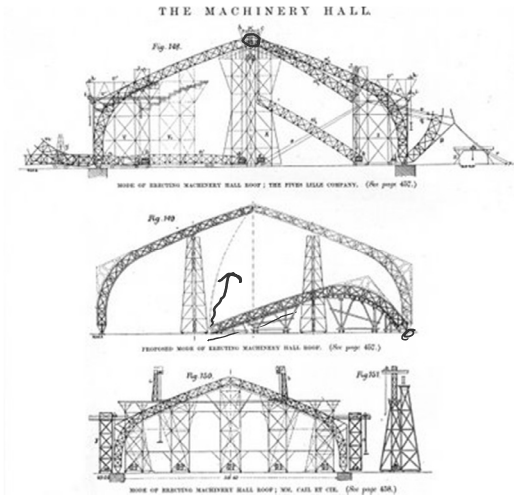

3-Hinged Arch analysis procedure

1. Determine all external loads.
 - find resultants of distributed loads (e.g. wind, snow, dead load)
2. Calculate vertical end reactions.
 - sum moments at each reaction
3. Draw an FBD of each side of the arch.
 - split at the hinge
4. Find the horizontal reactions.
 - sum moments at hinge
5. Find internal moments.
 - cut additional FBDs (e.g., at the knees)

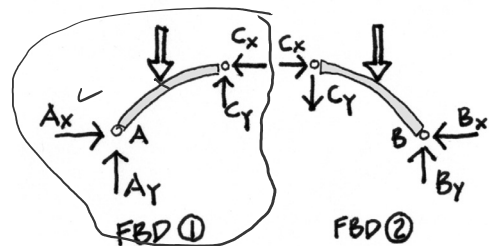
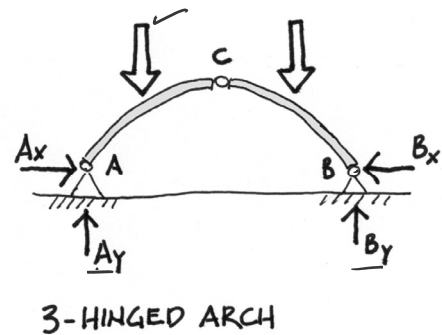

3-Hinged Arch even supports example 1

- Determine all external loads – find resultants of distributed loads (e.g. wind, snow, dead load)
 - Wind causes a pressure load, normal to the surface of the structure.
 - Wind can be positive pressure or negative suction and the pressure varies depending on the slope of the surface.
 - The pressure is typically expressed in PSF which translates to a PLF load on the members.

In this example with bents @ 10 ft. o.c.:

- wind on the wall is 25 PSF = 250 PLF
- wind on the roof is 10 PSF = 100 PLF

An FBD is drawn for a single bent (arch) of the structure.

The resultants of the uniform PLF loads are found in lbs.

Bent

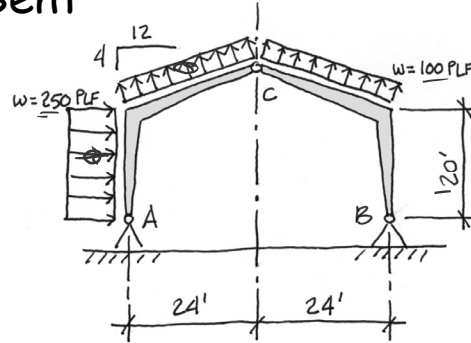

FBD

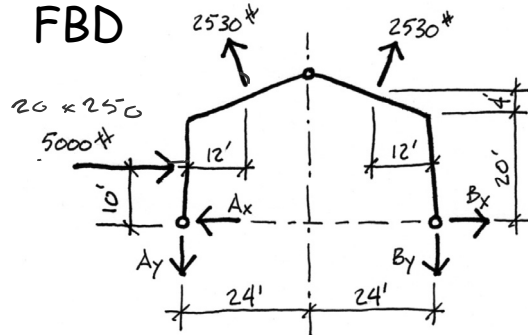

3-Hinged Arch even supports example 1

- Calculate the vertical end reactions.
 - sum moments at each reaction.

An FBD is drawn for a single bent of the structure.

The resultants of the uniform PLF loads are found and broken into horizontal and vertical components.

If the reactions are on the same horizontal, summing moments at either reaction will find the vertical component of the opposite reaction.

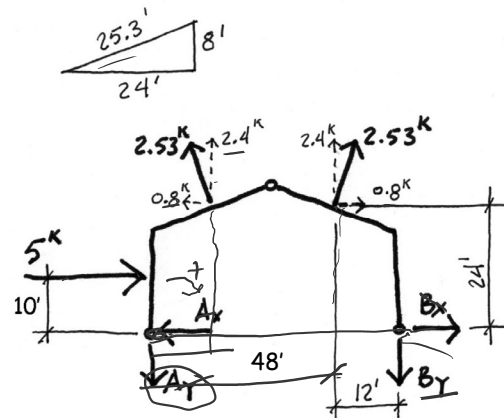

$$\sum M @ A \text{ to get } B_y = 1.36 \text{ k } \downarrow$$

$$\sum M @ B \text{ to get } A_y = 3.44 \text{ k } \downarrow$$

$$\sum M @ A = 0 \Rightarrow 5^k(10') - 0.8^k(24') - 2.4^k(12') - 24^k(36') + 0.8^k(24') + B_y(48')$$

$$B_y = 1.36^k$$

$$\sum M @ B = 0 = 5^k(10') + 2.4^k(36') + 2.4^k(12') - 0.8^k(24') + 0.8^k(24') - A_y(48')$$

$$A_y = 3.44^k$$

3-Hinged Arch even supports example 1

3. Draw an FBD of each side of the arch.

- split at the hinge.

4. Find the horizontal reactions

- sum moments at hinge.

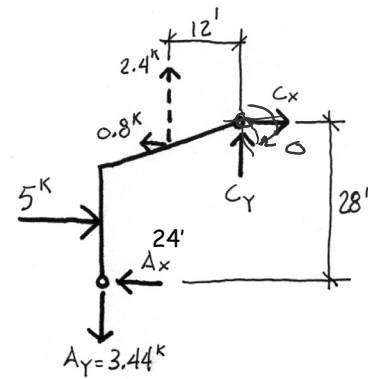

$$\sum M_C = 0 = 2.4^k(12') + 0.8^k(4') - 5^k(18') - 3.44^k(24') + \underline{A_x}(28')$$

$$A_x = \underline{5.02^k} \leftarrow$$

$$\sum M_C = 0 = -2.4^k(12') - 0.8^k(4') + 1.36^k(24') - \underline{B_x}(28')$$

$$B_x = 0.02^k \rightarrow$$

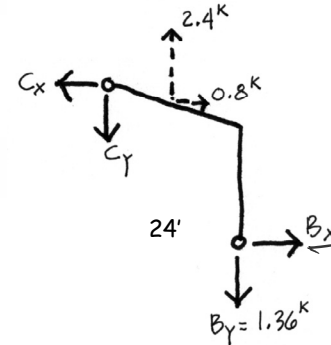

3-Hinged Arch even supports example 1

5. Find internal moments

- cut additional FBDs (e.g., at the knees).

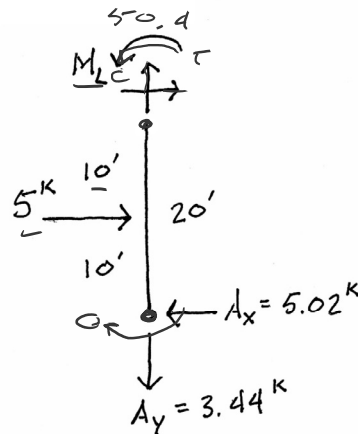

left wall

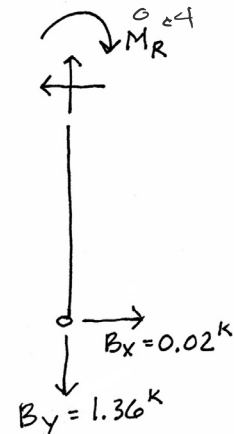

right wall

$$\sum M_L = 0 = +5.02^k(20') - 5^k(10') - M_L$$

$$M_L = \underline{50.4}'\text{-k}$$

$$\sum M_R = 0 = -0.02^k(20') + M_R$$

$$M_R = \underline{0.4}'\text{-k}$$

3-Hinged Arch even supports example 1

Internal moments can be calculated taking appropriate sections and FBD's.

The moment diagram is traditionally **drawn on the tension side** (the opposite of the convention used for beams).

Tension on the inside is called a positive moment regardless of rotation direction.

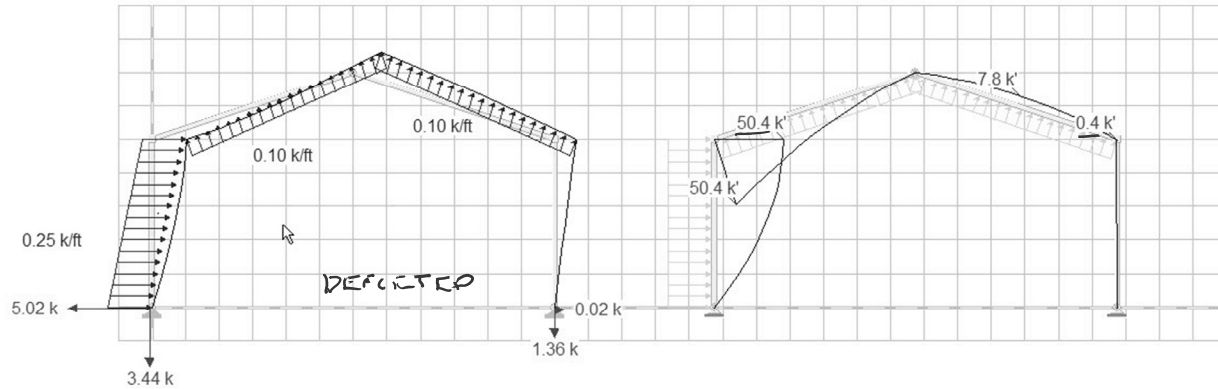

3-Hinged Arch Uneven Supports procedure

1. Sum moments at B
 - get an equation with A_h and A_v .
2. On left FBD sum moments at hinge
 - get a second equation for A_h and A_v
3. Solve the two equations for A_h and A_v
4. Repeat for right side or sum vertical and horizontal forces.

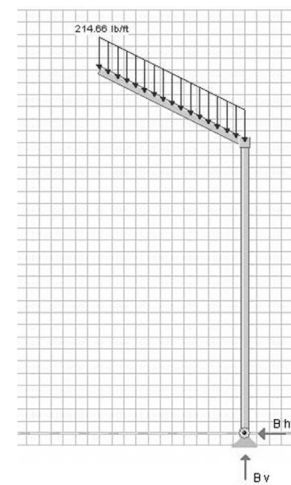
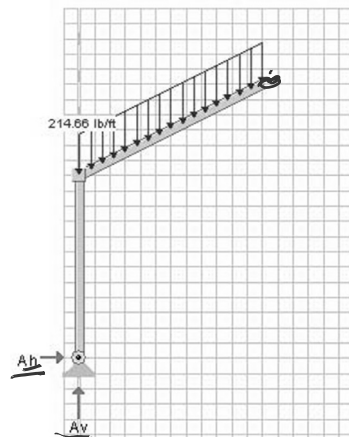
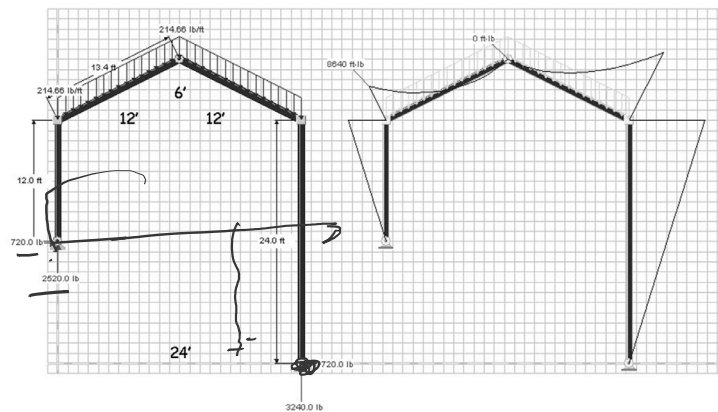

3-Hinged Arch Uneven Supports

example 2

1. Sum moments at B to get an equation with A_H and A_V .

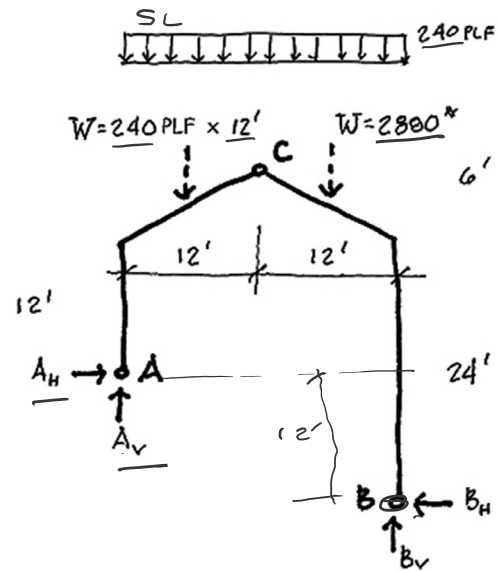

$$\sum M_{@B} = 0 = \underline{A_H}(12') + \underline{A_V}(24') - 2880*(18') - 2880*(6')$$

$$\underline{A_V} = -\underline{A_H}(0.5') + 2880$$

3-Hinged Arch Uneven Supports

example 2

2. On left FBD sum moments at hinge to get a second equation for A_H and A_V

$$\sum M_{@C} = 0 = -\underline{A_H}(18') + \underline{A_V}(12') - 2880(6')$$

$$\underline{A_V} = \underline{A_H}(1.5') + 1440$$

combining the two equations gives:

$$\begin{matrix} \sum \circ 1 \\ -\underline{A_H}(0.5') + 2880 \end{matrix} = \begin{matrix} \sum \circ 2 \\ \underline{A_H}(1.5') + 1440 \end{matrix}$$

$$\underline{A_H} = \underline{720}^*$$

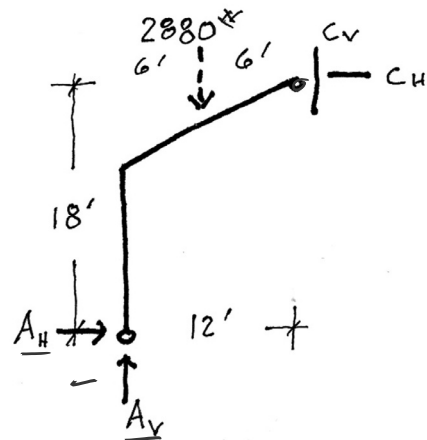

2. Solve the two equations for A_H and A_V

$$A_V = A_H(1.5) + 1440$$

$$A_V = 720(1.5) + 1440$$

$$A_V = \underline{2520}^*$$

3-Hinged Arch Uneven Supports

example 2

4. Repeat for right side or sum vertical and horizontal forces.

$$\sum F_V = 0 = 2520^* - 2880^* - 2880^* + B_V$$

$$B_V = 3240^*$$

$$\sum F_H = 0 = 720^* - B_H$$

$$B_H = 720^*$$

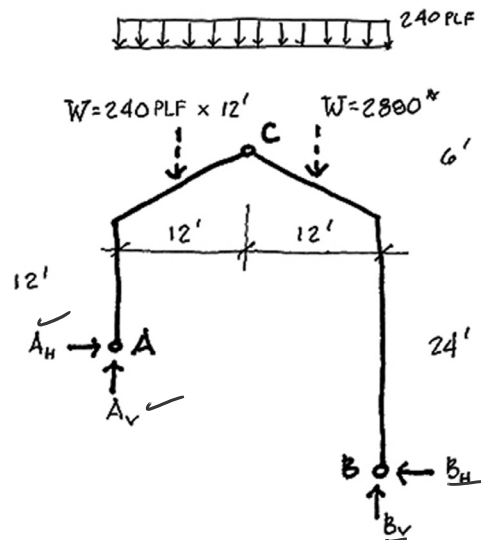

3-Hinged Arch Uneven Supports

example 2

5. Cut FBDs at knees to find internal moments

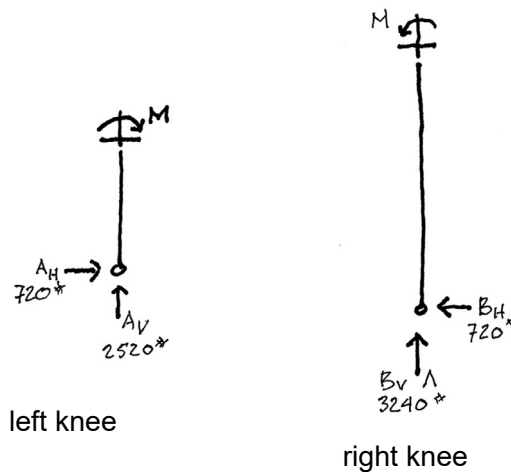

$$\sum M @ \text{LEFT KNEE} = 0$$

$$M_L - 720^*(12') = 0$$

$$M_L = 8640' - *$$

$$\sum M @ \text{RIGHT KNEE} = 0$$

$$-M_R + 720^*(24') = 0$$

$$M_R = 17280' - *$$

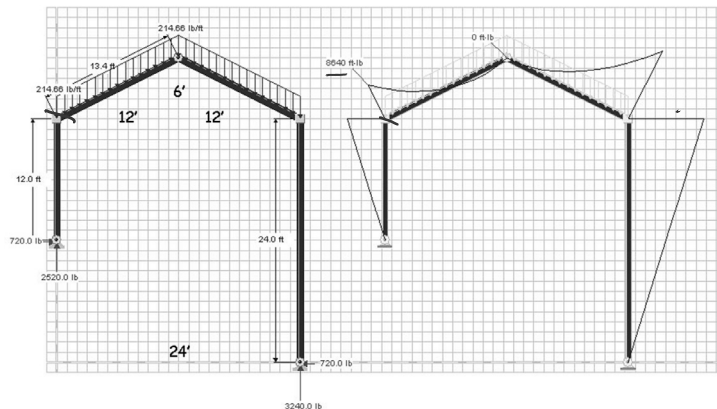

Sign Convention for Frames

Draw the moment on the tension side of the member.

The traditional convention is:

tension outside -

tension inside +

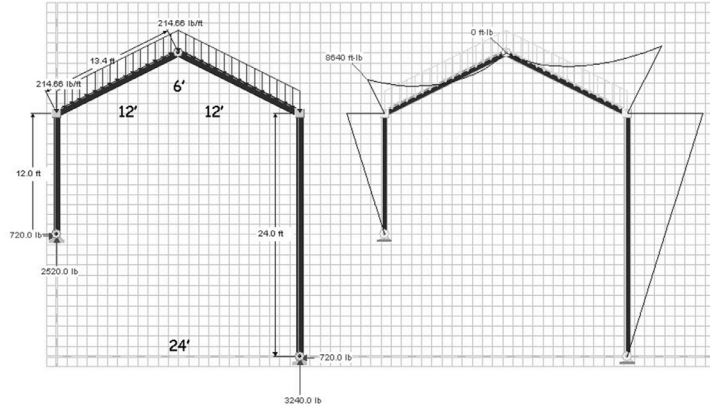

Here both knees have a negative moment

Examples and Details



Sydney Harbour Bridge

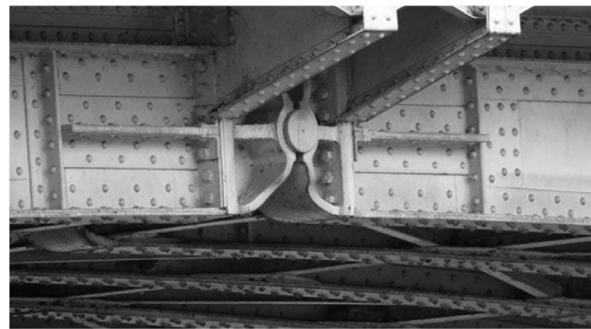

Center Hinge



The Iron Bridge
Telford England



Hinged Glulam Timbers

Keystone Wye Bridge

Glulam arches, spanning 160 ft.
built 1967-68 in South Dakota

