

Elasticity and Deformation

- Hooke's Law
- Young's Modulus
- Stress & Strain
- Deformation
- Thermal Effects

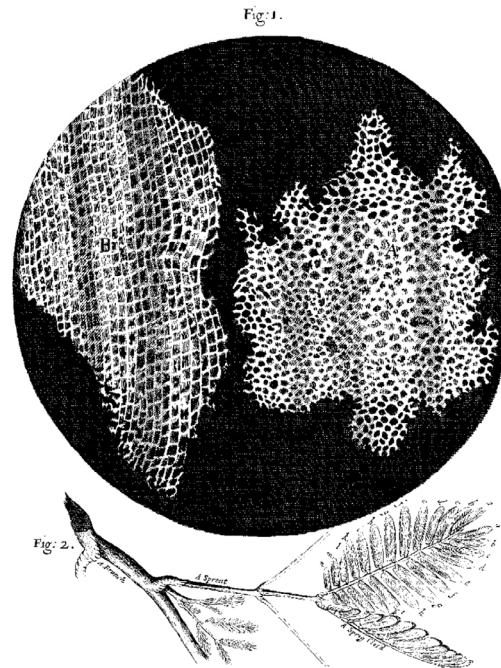

Robert Hooke, *Micrographia*

Robert Hooke

1635 - 1703

Hooke, referred to as the Leonardo da Vinci of England, was a prolific engineer, architect and polymath.

Studied at Christ's Church, Oxford w/ Boyle

Barometer

Curator of experiments of the Royal Society

Microscope (*Micrographia*)

Telescope – studied planets, Mars and Jupiter

Pocket watch

Universal joint

Surveyed London (after 1666 fire)

Wren's engineer (St Paul's dome)

Law of Springs (Hooke's Law)

Optics

Astronomy (gravity of bodies)



Portrait by Rita Greer, 2009

Hooke's Law

^{S.P.C}
 Ut tensio sic vis ^{F.S.P.C}
 STRETCH

$$D \propto P$$

The power of any Spring is in the same proportion with the Tension¹ thereof: That is, if one power stretch or bend it one space, two will bend it two, three will bend it three, and so forward. And this is the Rule or Law of Nature, upon which all manner of Restituent or Springing motion doth proceed.

Robert Hooke, *De Potentia Restitutiva*, 1678

With Cauchy's development of the concept of stress in 1822, Hooke's Law could be rewritten as:

$$\underline{\epsilon} \propto \underline{\sigma}$$

Strain is Proportional to Stress

¹ The Seventeenth Century meaning of Tension is like the Latin, tensio or our modern word, extension or deformation.

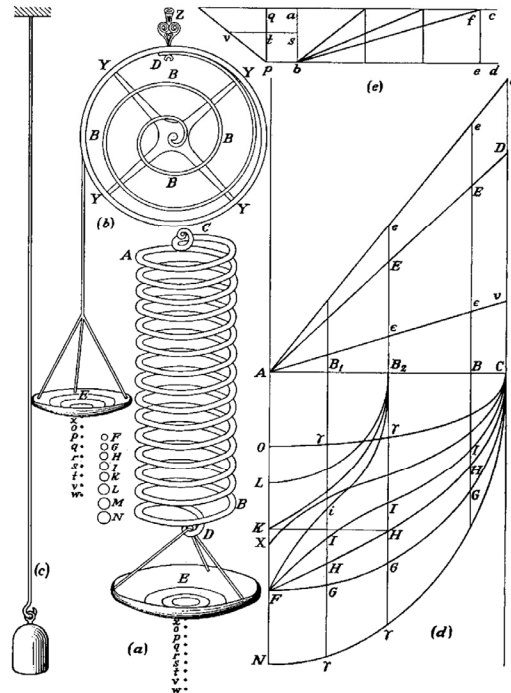

Young's Modulus

material stiffness

Young's Modulus, or the Modulus of Elasticity, is the material constant which generalizes Hooke's Law for any size member.

It is obtained by dividing the stress by the strain present in the material.

(Thomas Young, 1807)

$$E = \frac{P/A}{D/L} = \frac{\sigma}{\epsilon}$$

It thus represents a **measure of the stiffness of the material.**

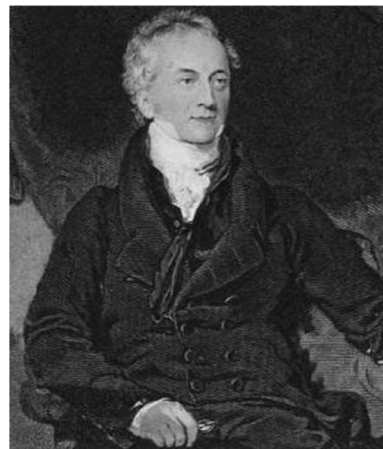

Thomas Young
1773 – 1829

Physics - Physiology - Egyptology

Young's Modulus

Young's Modulus or the Modulus of Elasticity, is obtained by dividing the stress by the strain present in the material. (Thomas Young, 1807)

$$E = \frac{P/A}{D/L} = \frac{\sigma}{\epsilon}$$

When graphing stress vs strain, the slope is the stiffness of the material.

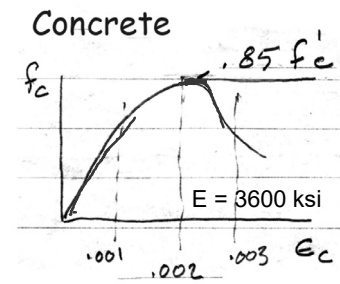
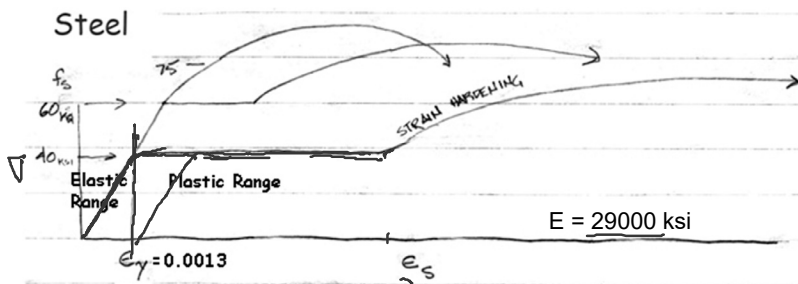
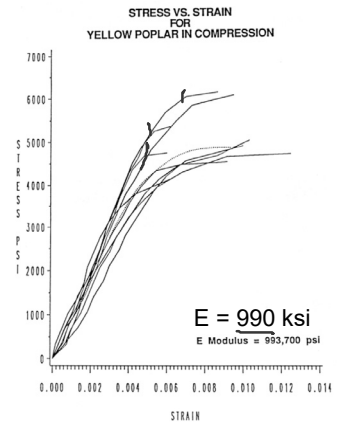

Young's Modulus

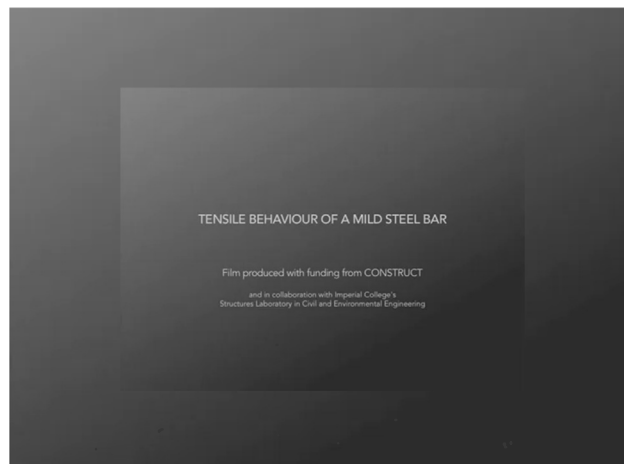

Stress

Stress is the result of some force being applied to an area of some material.

$$\sigma = \frac{P}{A}$$

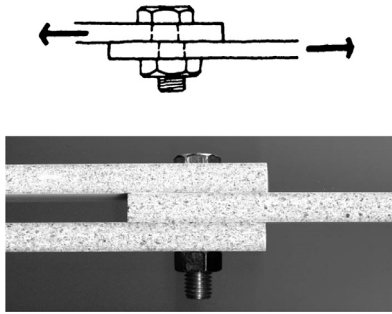

Shear Stress

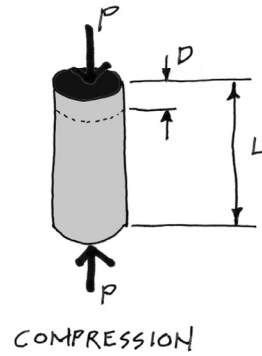
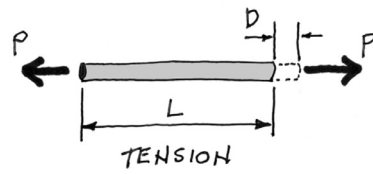

Strain

Strain is the amount of deformation in the material, per unit length.

$$\epsilon = \frac{D}{L}$$

Deformation occurs either in stretching (tension) or in compressing (compression) but not always at the same rate.

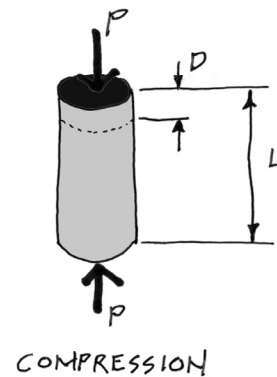
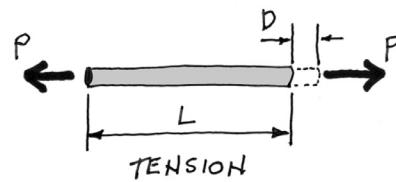
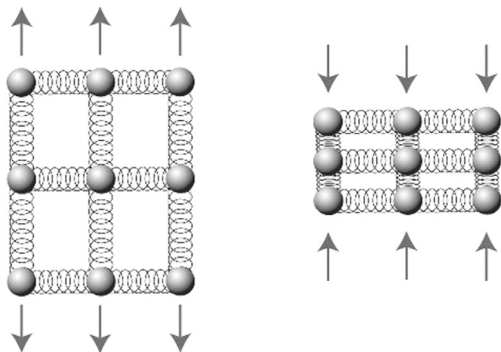

Deformation

Using the stress and the Modulus of Elasticity, the total deformation of an axially loaded member can be determined.

$$\varepsilon = \frac{D}{L}$$

and

$$E = \frac{\sigma}{\varepsilon} \rightarrow \varepsilon = \frac{\sigma}{E}$$

so

$$\frac{D}{L} = \frac{\sigma}{E} \rightarrow D = \frac{PL}{AE}$$

Deformation Equation

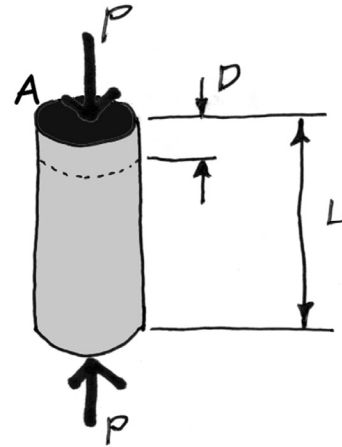

Stiffness

Deformation = Force x Stiffness

Axial

$$D = P \times \frac{L}{AE}$$

Force (P), STIFFNESS (L/AE), SECTION (A), MATERIAL (E), GEOMETRY (L)

Matrix formulation

$$\{\delta\} = \{F\}[K]$$

$$\{F\} = \{\delta\}[K]^{-1}$$

Flexure (constant moment)

$$D = M \times \frac{L^2}{4EI}$$

$$\begin{Bmatrix} F_1 \\ F_2 \end{Bmatrix} = \frac{AE}{L} \begin{bmatrix} 1 & -1 \\ -1 & 1 \end{bmatrix} \begin{Bmatrix} u_1 \\ u_2 \end{Bmatrix}$$

Strain Calculations

The amount of strain deformation is proportional to stress

$$D = \frac{PL}{AE} = \sigma \times \frac{L}{E}$$



Cable supported span of 866 ft
Jack height of 118 ft
Cable length 895 ft

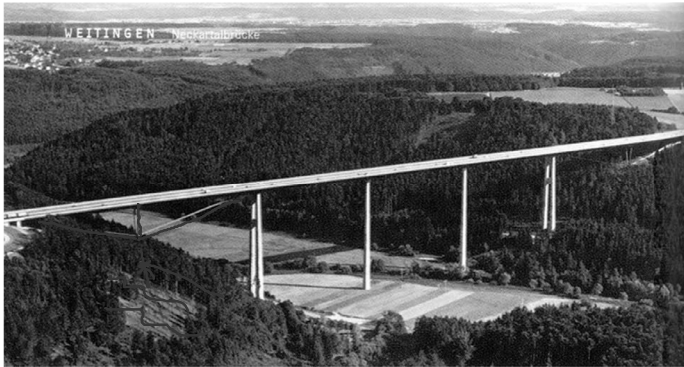

Neckar Viaduct at Weitingen
Engineer Fritz Leonhardt

Completed 1978
Span 2952 ft
Height 410 ft

Strain Calculations

The amount of strain deformation is proportional to stress

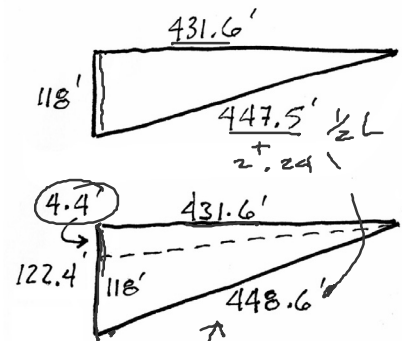
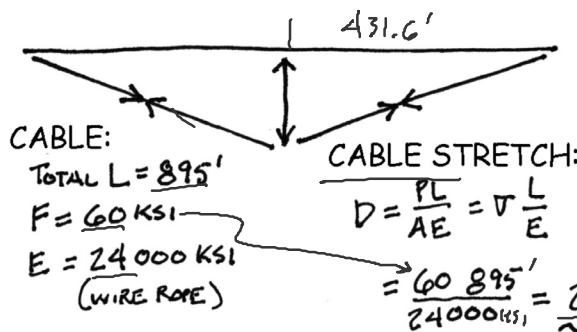

change in height due to stretch = 4.4'

Thermal Induced Stress

The amount of expansion with rising temperature or contraction with falling temperature is described by the ***coefficient of thermal expansion***.

$$\epsilon_t = c \cdot \Delta t$$

$$D = \epsilon_t \cdot L = c \cdot \Delta t \cdot L$$

If deformation is restrained, the result will be a thermal induced stress in the member.

$$\sigma_{\text{therm}} = E \cdot c \cdot \Delta t$$

The build-up of thermal stress is often prevented by expansion joints.

Material	Coefficient of Expansion In./In./Degree F.
Structural Steel	.0000065
Aluminum	.0000128
Wrought Iron	.0000067
Copper	.0000098
Brick	.0000035-.0000050
Cement Mortar	.0000070
Concrete	.0000055-.0000070
Limestone	.0000040
Plaster	.0000090
Wood (Fir), Parallel to Grain	.0000025
Wood (Fir), Perpendicular to Grain	.0000200-.0000300
Glass	.0000045
Plexiglas	.0000450-.0000500
Styrofoam	.0000400
Polyethylene	.0001000

Thermal Induced Stress

The amount of expansion with rising temperature or contraction with falling temperature is described by the ***coefficient of thermal expansion***.

$$\epsilon_t = c \cdot \Delta t$$

$$D = \epsilon_t \cdot L = c \cdot \Delta t \cdot L$$

If deformation is restrained, the result will be a thermal induced stress in the member.

$$\sigma_{\text{therm}} = E \cdot c \cdot \Delta t$$

The build-up of thermal stress is often prevented by expansion joints.

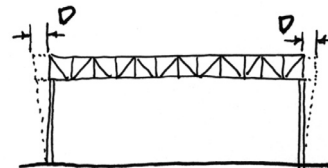
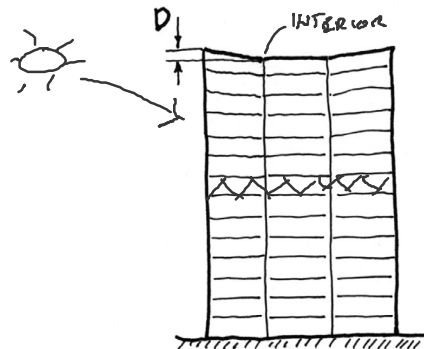

Thermal Induced Deformation

$$D = c \cdot \Delta t \cdot L$$

Thermal deformation, which results in cracking, is controlled with expansion joints.



University of Michigan, TCAUP

Structures I

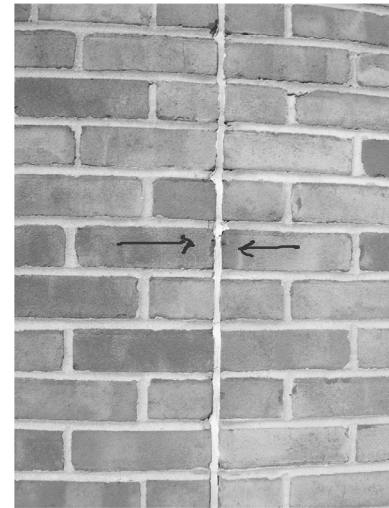

Expansion joint in wall

Expansion joints in wall 10 ft o.c.

Slide 15 of 16

Thermal Induced Deformation

How much will a 40' section of a concrete wall expand as temperature increases from 30°F to 90°F

c for concrete = 0.000006 "/"/°F

$$D = c \cdot \Delta t \cdot L$$

$$\begin{aligned} D &= c \Delta_T L \\ &= 6 \times 10^{-6} \cdot 60^\circ\text{F} \cdot 40' \left(\frac{12''}{1'} \right) \\ &= 0.173'' \end{aligned}$$

Material	Coefficient of Expansion In./In./Degree F.
Brick - - - - -	.0000035-.0000050
Cement Mortar - -	.0000070
Concrete - - - - -	.0000055-.0000070
Limestone - - - -	.0000040
Plaster - - - - -	.0000090

