

Bending and Shear in Simple Beams

Part 1

- Free Body Diagrams of Shear and Moment in Beams
- Sign Conventions for Plotting V & M Diagrams
- Diagrams by Equilibrium (FBD)
- Diagrams by Integration

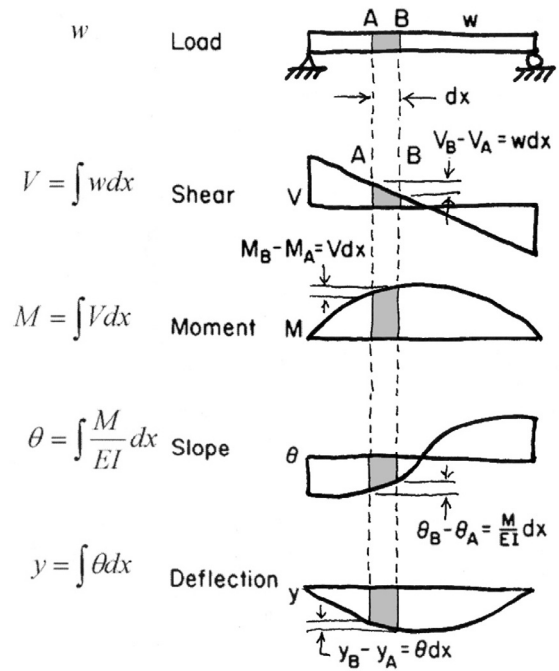

Beam Types

- Cantilever
- Simple
- Simple with Cantilever
- Continuous (multi-span)

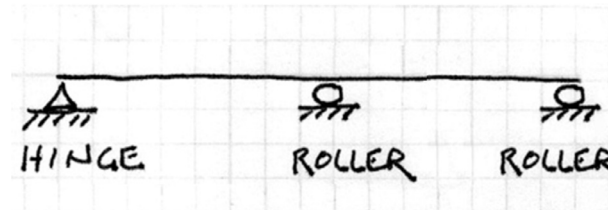
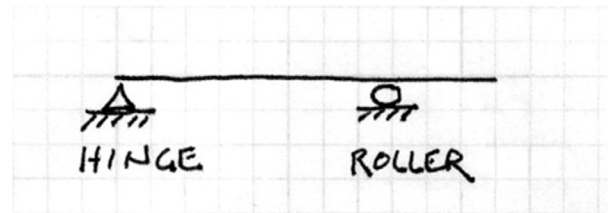
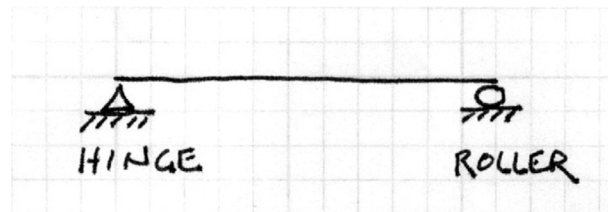
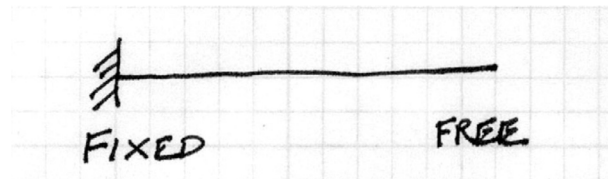

Support Conditions

Roller

Fixed in F_y

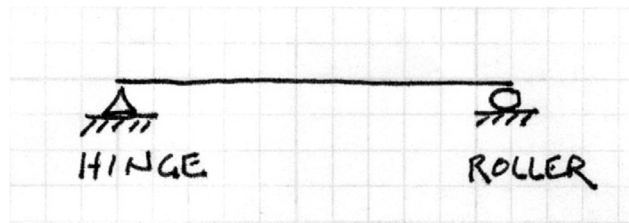

Hinge (Pinned)

Fixed in F_x

Fixed in F_y

Fixed

Fixed in F_x

Fixed in F_y

Fixed in M_z

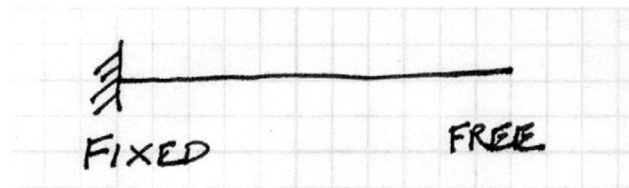

Connection Types

Bearing (or simple)



Slip Critical (or fixed)



Internal Shear and Moment

Cutting any section through a beam will reveal internal shear and moment forces necessary to maintain static equilibrium.

The shears can be determined by summing vertical forces and the moments by summing moments.

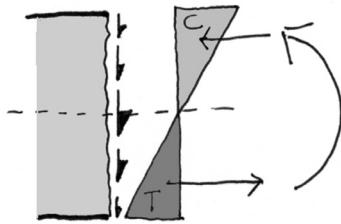
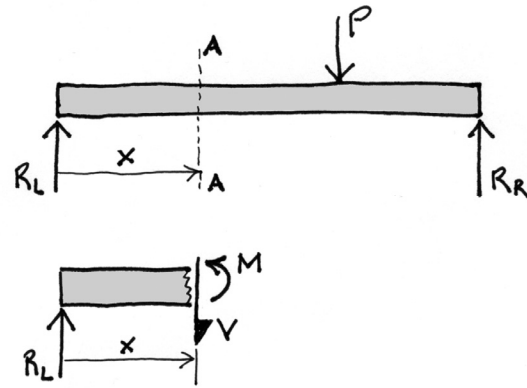

Sign Convention for Shear

- + the sum of the vertical forces to the left of the cut is upwards
- the sum of the vertical forces to the left of the cut is downwards

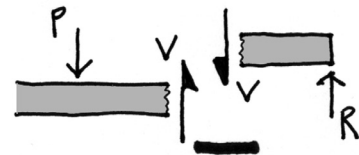
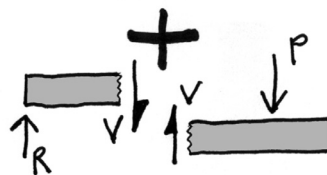

Sign Convention for Moment

- + the top fibers are in compression
- the top fibers are in tension

the European moment convention is the reverse



Sign Convention for Moment

+ positive curvature (holds water)

- negative curvature (spills water)

the European moment convention is the reverse

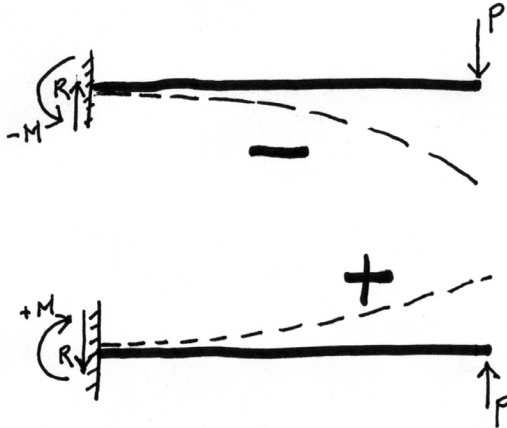
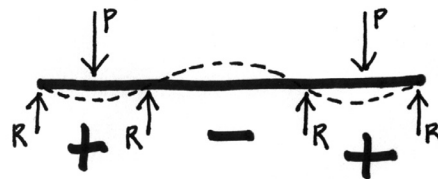
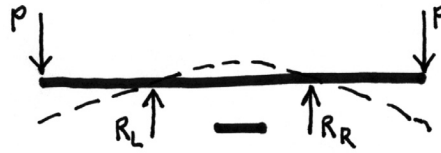
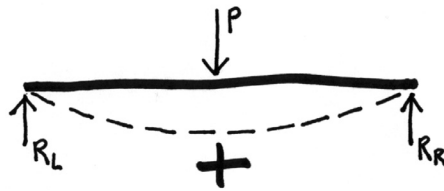

Relationships of Forces and Deformations

There are a series of relationships among forces and deformations in a beam, which can be useful in analysis. Using either the deflection or load as a starting point, the following characteristics can be discovered by taking successive derivatives or integrals of the beam equations.

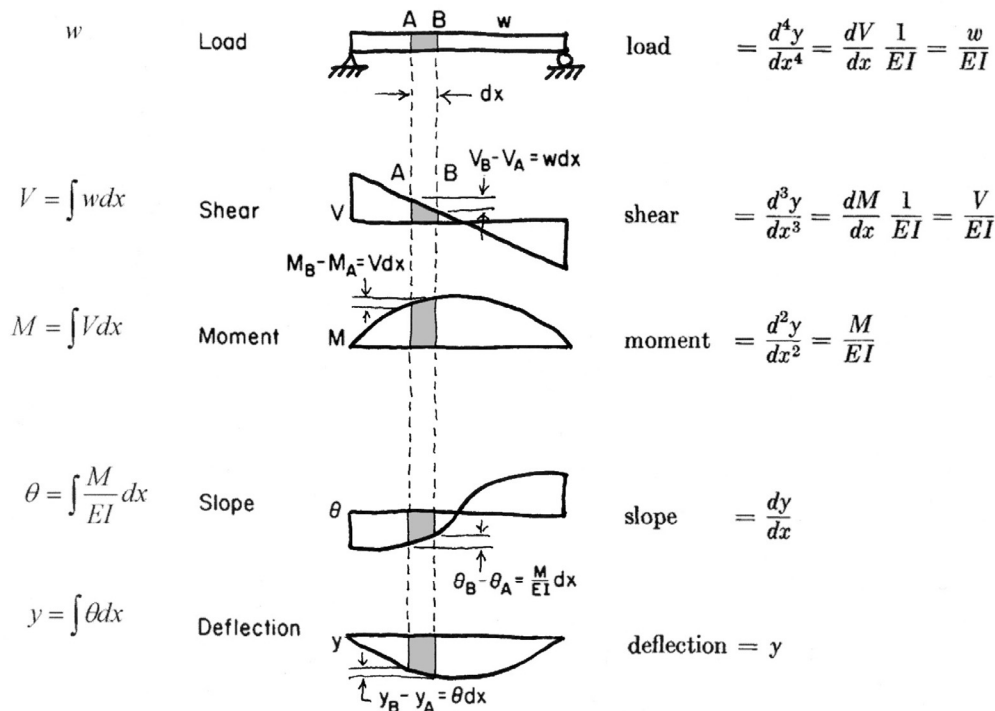

Methods to Determine Values of Shear and Moment

1. Equilibrium Method

- Select a point along the beam
- Cut a section and draw the FBD
- Solve for the internal shear and moment forces at the section

2. Integration of Equations

- Write the equation of the load function
- Integrate load equation to get shear equation
- Solve integration constant (use end reaction)
- Integrate shear equation to get moment equation
- Solve integration constant (use point with zero moment, e.g. end point)

3. Semi-graphical Method

- Draw load diagram and solve end reactions with equilibrium equations.
- Start at left and construct the shear diagram using point loads and areas on load diagram
- Calculate areas of shear diagram to find change in value on moment diagram
- Find points of zero moment to begin moment diagram, e.g. end points

4. Superposition of Equations

- Break the loading into standard cases
- Use given equations to solve shear and moment for each case
- Add the cases to get combined values of original loading

1. Equilibrium Method - procedure

To plot the change of internal shear or moment forces, **a series of sections can be cut** along the beam. The exposed forces can be calculated.

A section should **not be cut “through” an applied force**, but either a bit to the left or to the right of the force.

Either the “left” or “right” free body diagram may be used to calculate the forces. The sign convention described earlier must be consistently applied.

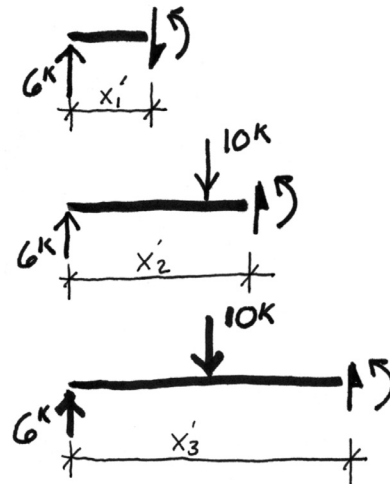
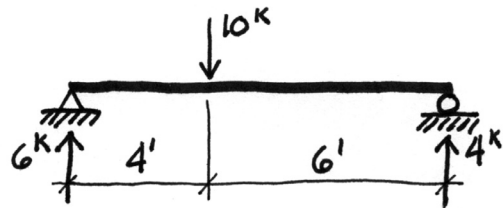

1. Equilibrium Method - example

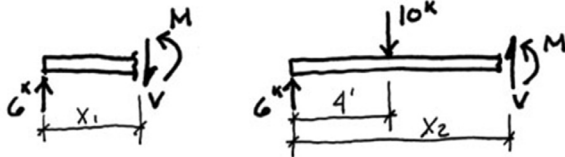

Tabulated Results of FBD Calculations

Cut Location	Shear	Moment
From R_L (ft)	V (k)	M (k-ft)
0-	0	0
0+	6	0
1	6	6
2	6	12
3	6	18
4-	6	24
4+	-4	24
5	-4	20
6	-4	16
7	-4	12
8	-4	8
9	-4	4
10-	-4	0
10+	0	0

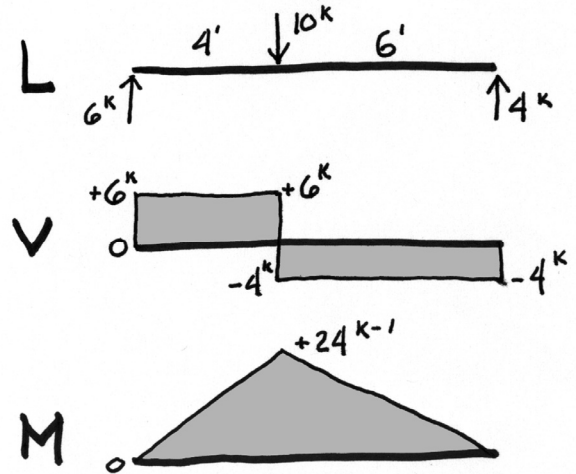

1. Equilibrium Method - example

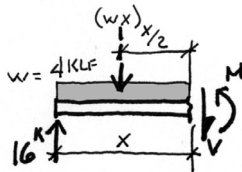

Tabulated Results of FBD Calculations

Cut Location	Shear	Moment
From R_L (ft)	V (k)	M (k-ft)
0-	0	0
0+	16	0
1	12	14
2	8	24
3	4	30
4	0	32
5	-4	30
6	-8	24
7	-12	14
8-	-16	0
8+	0	0

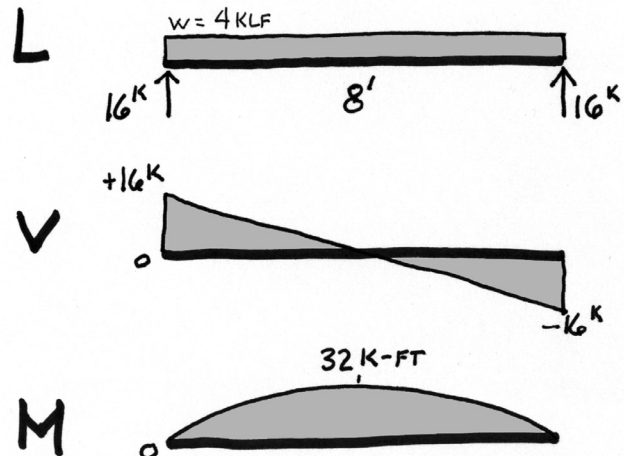

1. Equilibrium Method - example

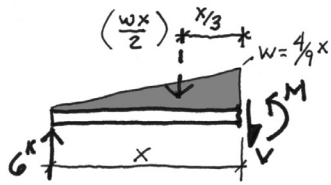

Tabulated Results of FBD Calculations

Cut Location From R_L (ft)	Shear V (k)	Moment M (k-ft)
0-	0	0
0+	6	0
1	5.78	6.9
2	5.11	11.4
3	4.00	16.0
4	2.44	19.3
5	0.44	20.74
5.2	0	20.78
6	-2.00	20.0
7	-4.90	16.6
8	-8.24	10.0
9-	-12.00	0
9+	0	0

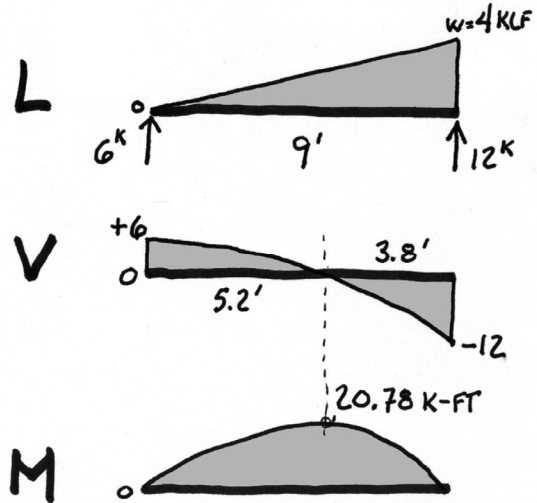

Relationships of Forces and Deformations - procedure

There are a series of relationships among forces and deformations in a beam, which can be useful in analysis. Using either the deflection or load as a starting point, the following characteristics can be discovered by taking successive derivatives or integrals of the beam equations.

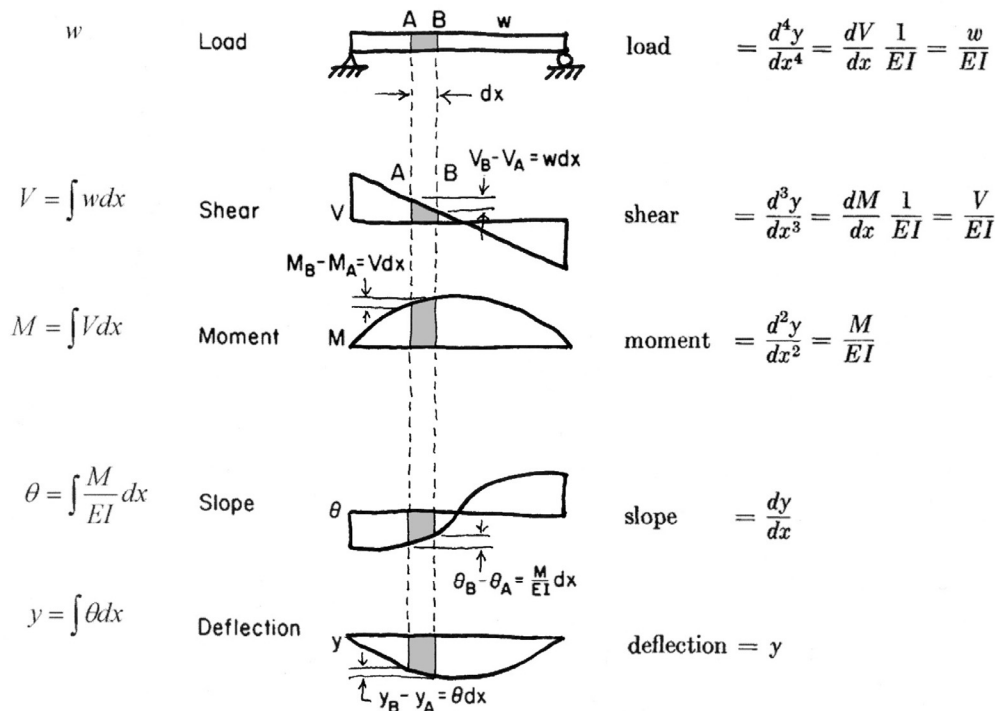

2. Shear and Moment by Integration - example

One method of solving shear and moment forces is to write the loading equation and solve the integration equations for the shear and moment. One problem using this method can be finding the constant of integration, particularly with discontinuous load functions.

$$-w$$



$$V = \int w dx$$

$$V = -wx + C$$

$$V = -wx + \frac{wl}{2}$$

Shear

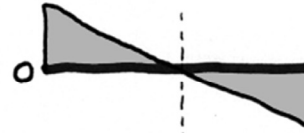

$$M = \int V dx$$

$$M = -\frac{w}{2}x^2 + \frac{wl}{2}x + C$$

$$M = -\frac{w}{2}x^2 + \frac{wl}{2}x$$

Moment

