

# Shear Stresses in Beams

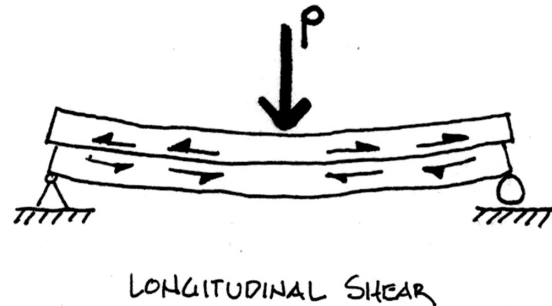
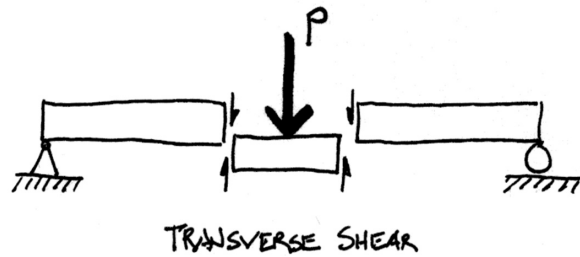

- Shear Stress
- Horizontal Shear
- Shear Profile
- Shear Design
- Shear Connections
- Principal Stress

## Shear Force and Shear Stress

Shear force is an internal force present at a cut section.

The shear force,  $V$ , is the force graphed in a Shear Diagram, and related to the moment.

Shear stress is that force distributed across the section of the beam. Just like flexure stress, this distribution is not uniform across the section.

In observing an FBD of an elemental square, notice that both horizontal and vertical shear stresses are present.

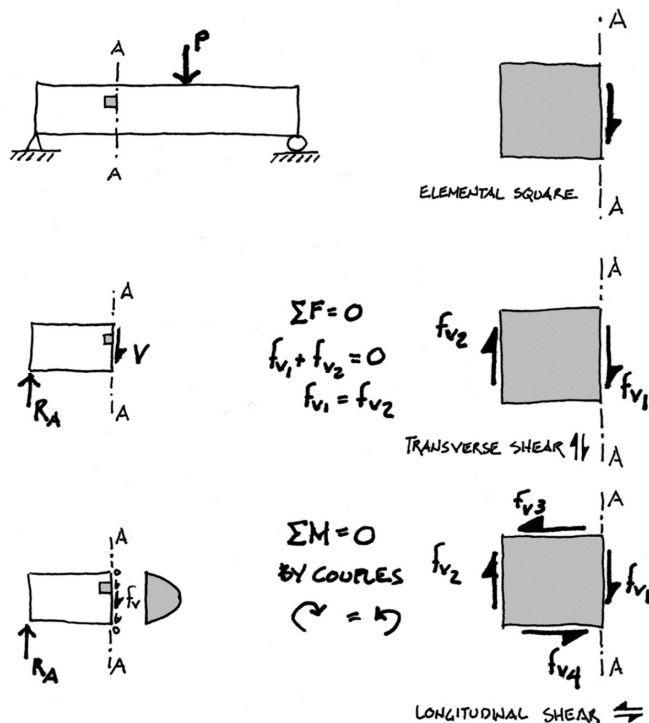

# Shear Direction

At any particular point in the beam, both horizontal and vertical shear stress are equal.

Depending on the material, either horizontal or vertical shear may be critical.

# Critical Shear Location

The critical location of shear stress can be found by using the stress equation.

$$f_v = \frac{VQ}{Ib}$$

Shear stress will be maximum at locations where:

- V is high (usually reactions)
- Q is high (at neutral axis,  $Ax$ )
- b is low (in a thinner web)
- I is low (in a less stiff section)

For prismatic sections, I and b are constant over the beam length.

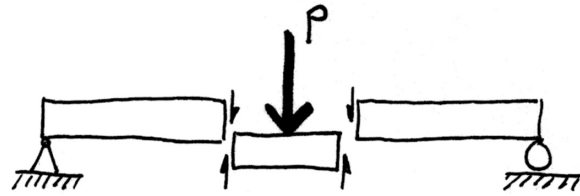

TRANSVERSE SHEAR

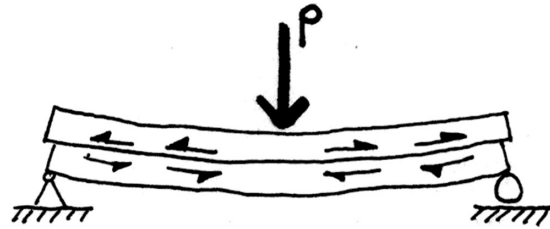

LONGITUDINAL SHEAR

# Shearing Unit Stress in Beams

Considering shear and moment in a beam:

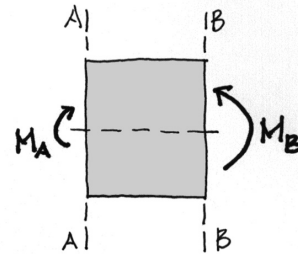
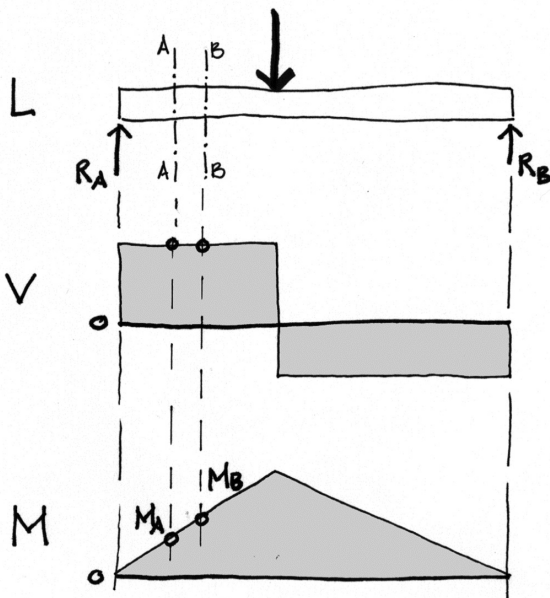

Taking a beam section between points A and B, the moment  $M_A < M_B$

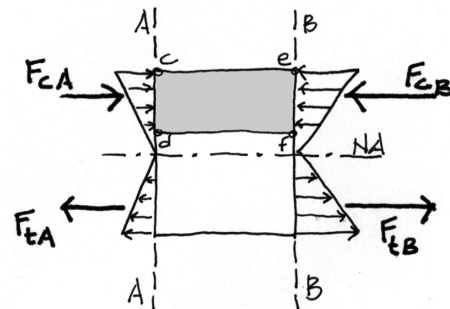

Therefore,  $F_{cA} < F_{cB}$  and  $F_{tA} < F_{tB}$

# Shearing Unit Stress in Beams (cont.)

Since,  $F_{cA} < F_{cB}$  and  $F_{tA} < F_{tB}$

In the FBD

$$C_1 < C_2$$

Therefore by  $\Sigma F_H=0$ ,  $V_h = C_2 - C_1$

$V_h$  spread over the surface between A and B is the horizontal shear stress at that section.

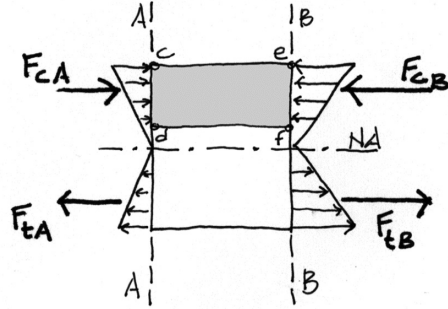

This horizontal shear stress can be determined by

$$f_v = \frac{VQ}{Ib} \quad \text{where,} \quad Q = A\bar{x}$$

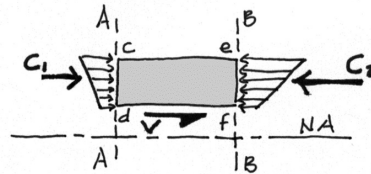

# Shear Stress Analysis Procedure

1. Draw the shear diagram and find  $V_{max}$ .
2. Determine least width,  $b_{min}$ .
3. Calculate  $I$ .
4. Calculate  $Q$  for the section.  $Q_{max}$  at N.A.
5. Calculate  $f_v = VQ/Ib$ .

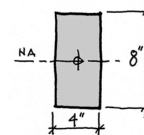
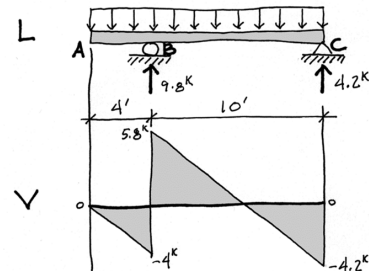

$$f_v = \frac{VQ}{Ib}$$

## Shear Stress Analysis - example

Given:

beam section  
Beam span and loading

Find:

maximum shear stress and location

$$f_v = \frac{VQ}{Ib}$$

1. Draw the shear diagram and find  $V_{\max}$ .

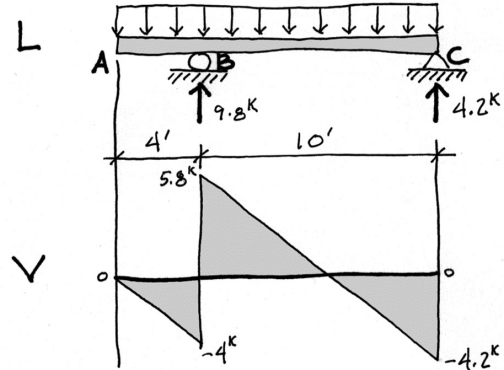
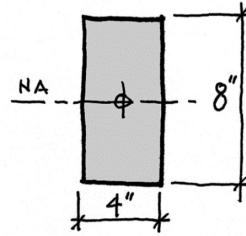

## Shear Stress Analysis - example

$$f_v = \frac{VQ}{Ib}$$

2. Determine least width,  $b_{\min}$ .

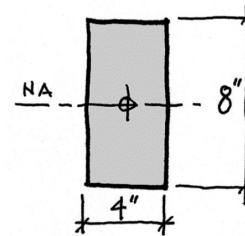

3. Calculate  $I$ .

$$I = \frac{bh^3}{12} = \frac{4(8^3)}{12}$$

$$= 171 \text{ in}^4$$

# Shear Stress Analysis - example

4. Calculate Q for the section.  
 $Q_{max}$  is at the N.A.

$$Q = A\bar{x}$$

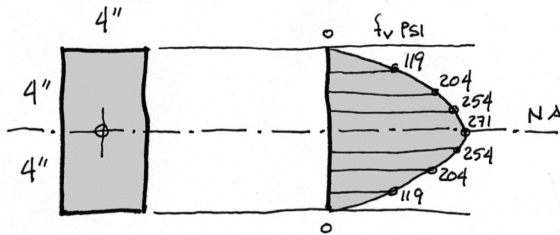

5. Calculate  $f_v = VQ/Ib$ .

$$f_v = \frac{VQ}{Ib} = \frac{5800 \times 32}{171 \times 4} = 271.3 \text{ psi}$$

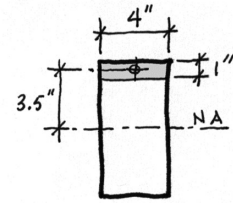

$$Q = 14 \text{ in}^3$$

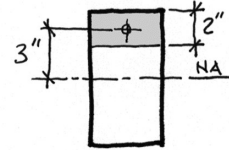

$$Q = 24 \text{ in}^3$$

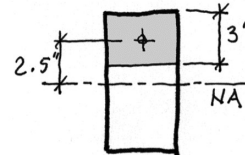

$$Q = 30 \text{ in}^3$$

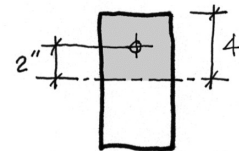

$$Q = 32 \text{ in}^3$$

## Shear Stress in Common Shapes

The shear distribution in 3 common profiles is shown at the right.

Notice that if  $b$  is constant or thin at the centroidal axis, then the maximum shear occurs there. This is usually the case.

If, however, the section is wider at the centroidal axis, the maximum stress may be located at a level where the section is thinner.

Abrupt changes in width, result in abrupt changes in stress level.

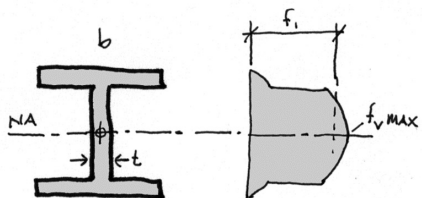
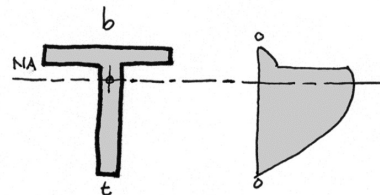
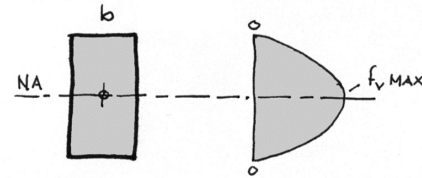

$$f_v = \frac{VQ}{Ib}$$

# Shear in Common Shapes

For common shapes some special formulas are used. In **rectangles**, inserting  $b$  and  $h$  into the equations of  $I$  and  $Q$  will give:

$$f_v = \frac{VQ}{Ib} = \frac{3V}{2A}$$

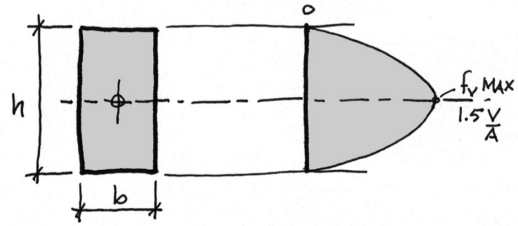

In **W, C and I sections**, because the average shear stress is just a bit less than the actual maximum, but much easier to calculate, the average is used:

$$f_{v\_AVG} = \frac{V}{t_w d}$$

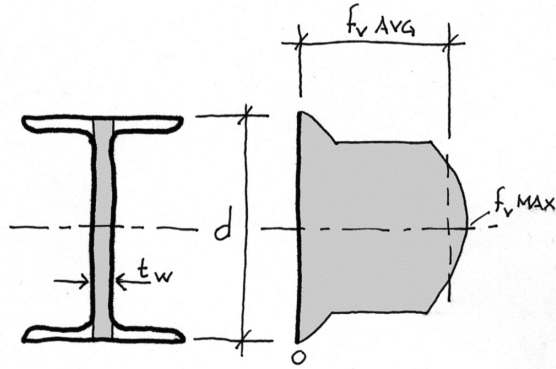

# Design for Shear - Wood

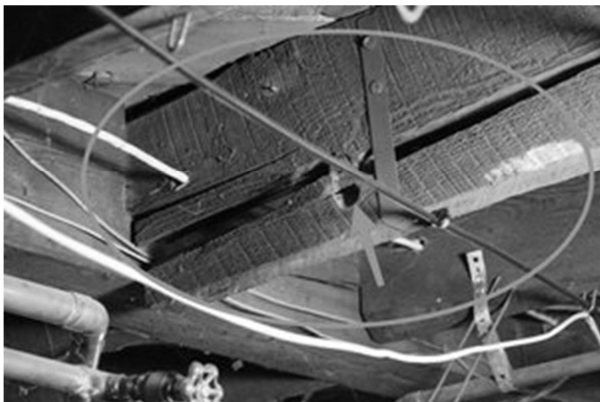
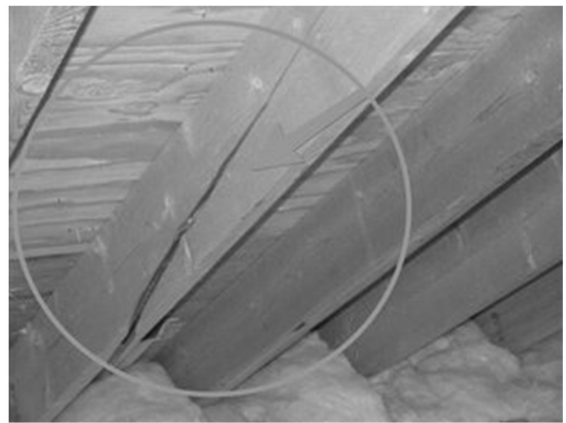
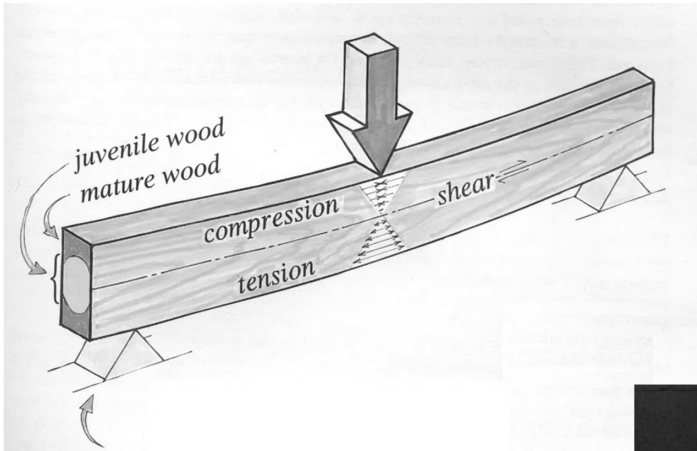

# Design for Shear

## Steel

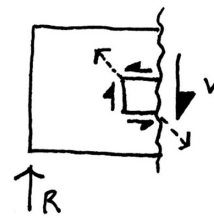
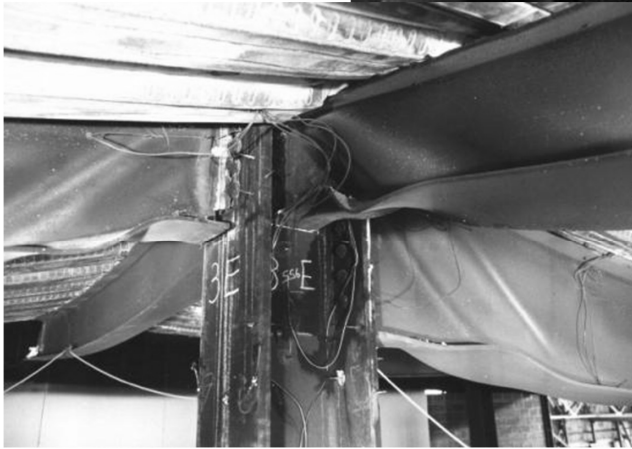

# Shear in Steel Beams

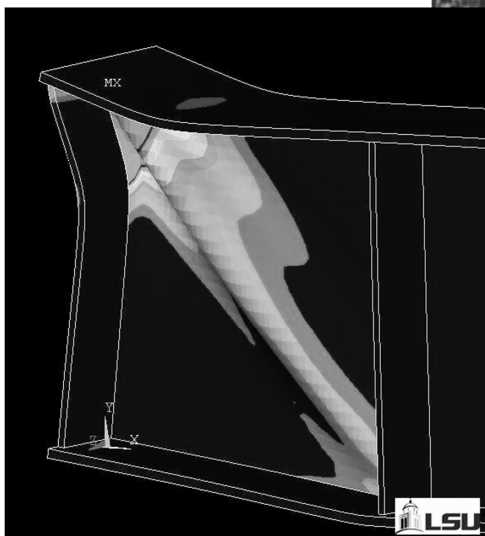
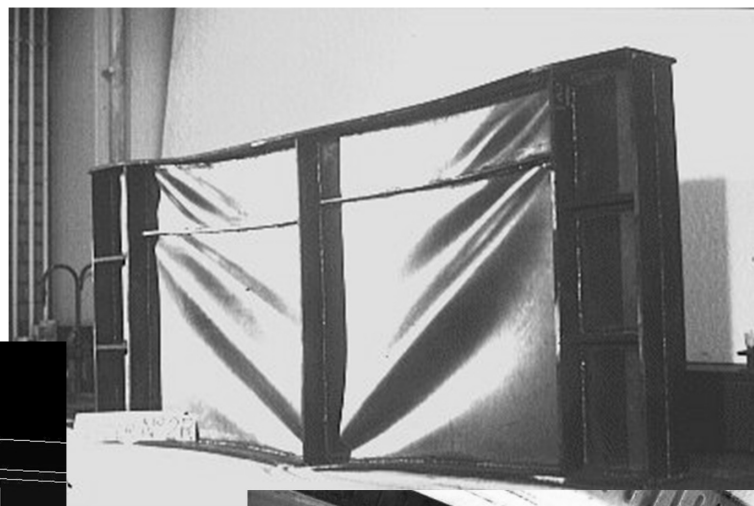

# Design for Shear

## Concrete

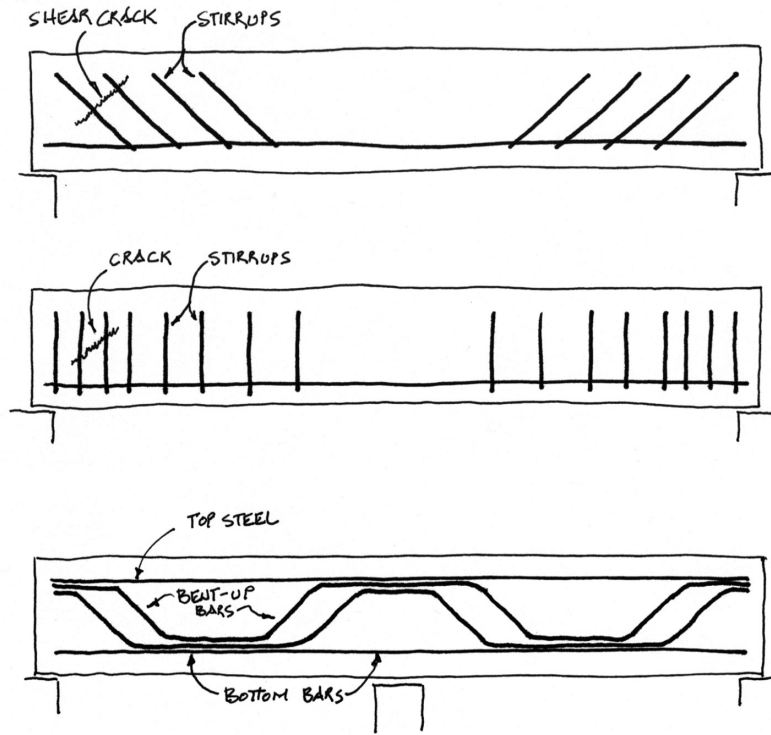
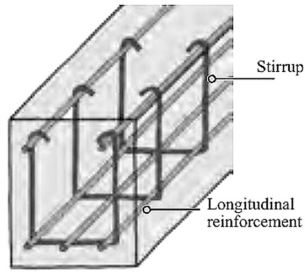
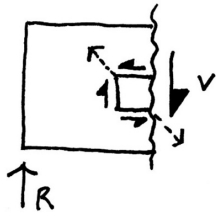

# Design for Shear - Connections

- Dependent on shear stress at connection
- Shear area depends on spacing of connectors
- Connector spacing may vary depending on V

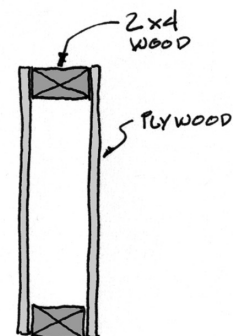
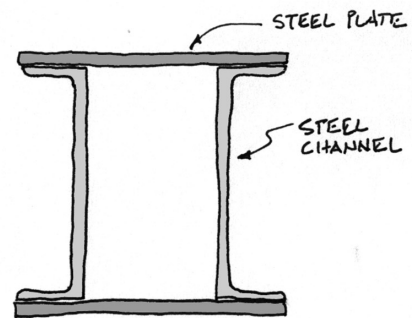



# Design of Shear Connectors

The connections at the planes of contact of any built-up section must be able to transmit the shear stress across that plane.

The following example shows a box-beam section which uses nails to connect the plywood sides to the 2x4 top & bottom plates.

Because the shear force, V, varies linearly across the length of the beam, the spacing of the nails can also vary for increased economy.

$$f_v = \frac{VQ}{Ib}$$

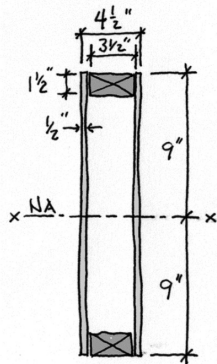

$$I = \frac{b_s d_s^3}{12} - \frac{b_v d_v^3}{12}$$

$$I = \frac{4.5 * 18^3}{12} - \frac{3.5 * 15^3}{12}$$

$$I = 1202.6 \text{ in}^4$$

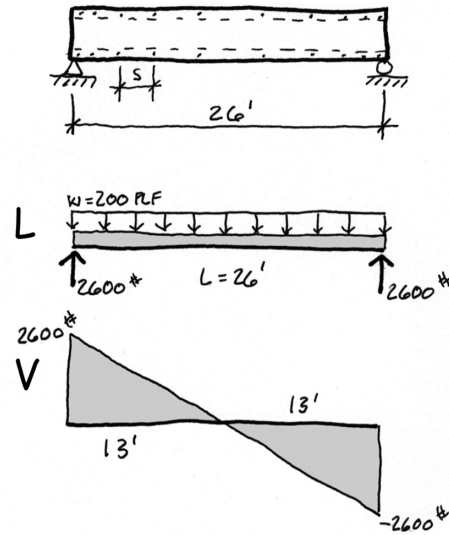

# Design of Shear Connectors

Q is based on the area which 'slides' in relation to the beam (area above the cut). In this case the 2x4 (actually 1.5x3.5) is the area which 'slides' in relation to the plywood sides. The stress which is determined, can be seen as acting on the contact surface of the shear planes. b is the distance across the shearing surface. With 2 shear planes the surface area is doubled (b = 1.5" x 2).

$$f_v = \frac{VQ}{Ib}$$

$$V_{max} = 2600\#$$

$$I = 1202.6 \text{ in}^4$$

$$Q = A\bar{x} = (3.5 \text{ in} \times 1.5 \text{ in}) 8.25 \text{ in} = 43.3 \text{ in}^3$$

$$b = 1.5 \text{ in} \times (2 \text{ sides})$$

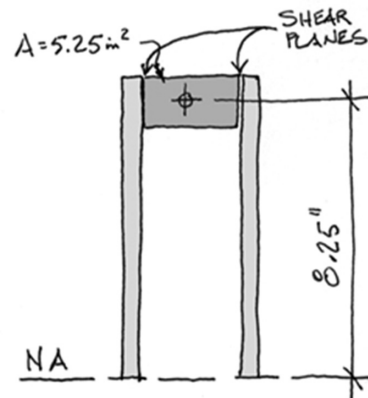

The force on the shear plane is  $P = f_v A_v$ , where  $A_v$  is the shear surface area. To find the force on a pair of nails ( $p_s$ ) use the area surrounding those 2 nails (1/2 distance to adjacent nails times b).

$$p_s = f_v A_{vs} = \frac{VQ}{Ib} b s = \frac{VQs}{I}$$

$$s = \frac{p_s I}{VQ}$$

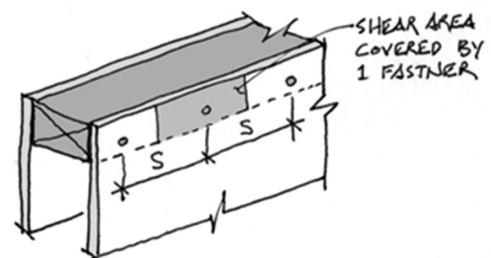

# Design of Shear Connectors

The capacity of the nail is obtained from a table based on the nail size and wood type. Using the given capacity of  $p_s = 80\# / \text{nail}$  and using a pair of 2 nails per space (one each side) the equation becomes:

$$s = \frac{p_s I}{VQ} = \frac{80\# (2) (1202.6 \text{ in}^4)}{2600\# (43.3 \text{ in}^3)} = 1.71 \text{ in}$$

$\therefore$  use 1.5"

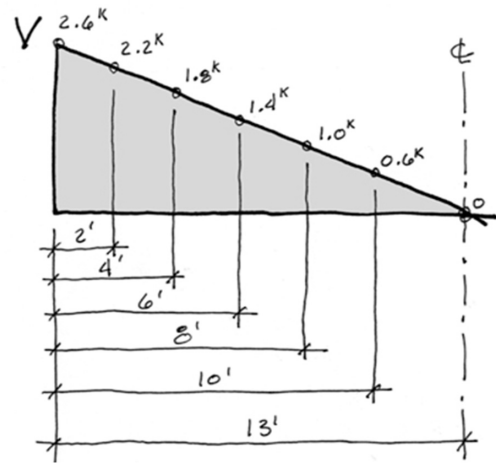

## NAILS

**Table 12S POST FRAME RING SHANK NAILS: Reference Lateral Design Values, Z, for Single Shear (two member) Connections<sup>1,2,3</sup>**

for sawn lumber or SCL with both members of identical specific gravity (tabulated lateral design values are calculated based on an assumed length of nail penetration, p, into the main member equal to 10D)

Side Member Thickness $t_s$ in.	Nail Diameter D in.	Nail Length L in.	Reference Lateral Design Values, Z, for Single Shear (two member) Connections <sup>1,2,3</sup>									
			G=0.67 Red Oak	G=0.55 Mixed Maple Southern Pine	G=0.5 Douglas Fir-Larch	G=0.49 Douglas Fir-Larch (N)	G=0.46 Douglas Fir(S) Hem-Fir(N)	G=0.43 Hem-Fir	G=0.42 Spruce-Pine-Fir	G=0.37 Redwood (open grain)	G=0.36 Eastern Softwoods Spruce-Pine-Fir (S) Western Cedars Western Woods	G=0.35 Northern Species
1/2	0.135	3, 3.5	114	89	80	78	73	67	65	57	56	54
	0.148	3 - 4.5	127	100	89	87	81	75	73	64	63	61
	0.177	3 - 8	173	139	125	122	115	107	105	93	91	88
	0.200	3.5 - 8	188	151	137	134	126	118	115	102	100	95
	0.207	4 - 8	193	156	142	138	131	122	119	106	102	96

# Design of Shear Connectors

$$s = \frac{p_s I}{VQ} = \frac{80\# (2) (1202.6 \text{ in}^4)}{2600\# (43.3 \text{ in}^3)} = 1.71 \text{ in}$$

$\therefore$  use 1.5"

This gives the spacing at the ends where the  $V=2600\#$ . At other locations along the beam, the spacing can be found by substituting the appropriate  $V$  into the equation above. Usually, the increment,  $s$ , is rounded to the nearest half inch.

A total number of nails can be found based on the average force  $V_{avg}$  to get an average spacing,  $s_{avg}$ , and then dividing the total length by  $s_{avg}$ .

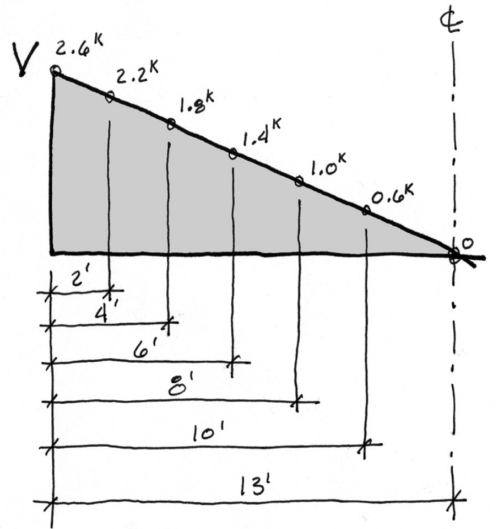

$$s_{avg} = \frac{p_s I}{V_{avg} Q} = \frac{80\# (2) (1202.6 \text{ in}^4)}{1300\# (43.3 \text{ in}^3)} = 3.42 \text{ in}$$

$$N_{total} \text{ per side} = \frac{L}{s_{avg}} = \frac{26 \text{ ft} \cdot 12 \text{ in}}{3.42 \text{ in} \cdot \text{ft}} = 91.27 \text{ nails}$$

$\therefore$  use 92 nails/side

o.c. s	V lbs.	from end
1.5"	2963	0
2"	2222	1'-11"
4"	1111	7'-5"
6"	741	9'-4"
	0	13'-0"

# Plywood box beam

