

## Deflection of Structural Members

- Slope and Elastic Curve
- Deflection Limits
- Diagrams by Parts
- Symmetrical Loading
- Asymmetrical Loading
- Deflection Equations and Superposition



## Deflection

Axial fiber deformation in flexure results in normal (vertical) deflection.

The change in lengths, top and bottom, results in the material straining. For a simple span with downward loading, the top is compressed and the bottom stretched.

The material strains result in corresponding stresses. By Hooke's Law, these stresses are proportional to the strains which are proportional to the change in length of the radial arcs of the beam "fibers".

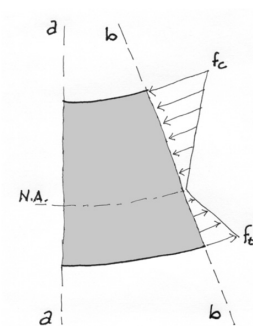
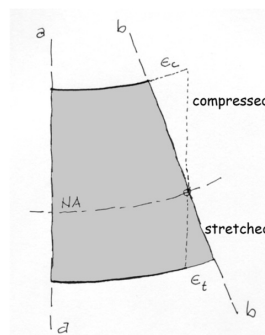
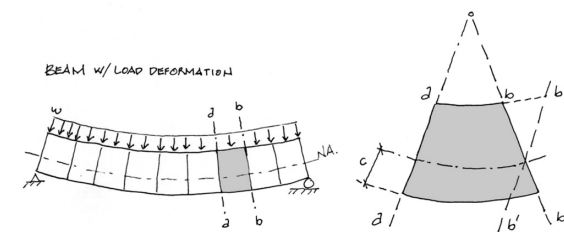
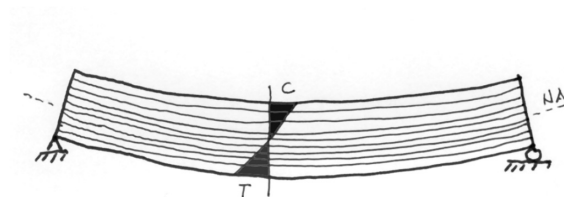

## Slope

- The curved shape of a deflected beam is called the **elastic curve**

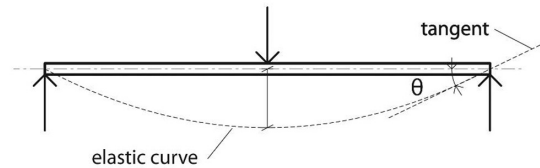

- The angle of a tangent to the elastic curve is called the **slope**, and is measured in radians.

$$\text{degrees} = \text{radians} \frac{180}{\pi}$$

- Slope is influenced by the **stiffness** of the member:
  - material stiffness **E**, the modulus of elasticity
  - sectional stiffness **I**, the moment of inertia,
  - as well as the length of the beam, **L**

$$\text{Stiffness} = \frac{EI}{L}$$

## Deflection

- Deflection is the distance that a beam bends from its original horizontal position, when subjected to loads.

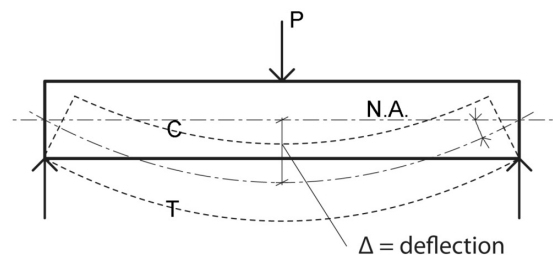

- The compressive and tensile forces above and below the neutral axis, result in a shortening (above n.a.) and lengthening (below n.a.) of the longitudinal fibers of a simple beam, resulting in a curvature which deflects from the original position.

### Axial Stiffness

$$\text{Stiffness} = \frac{EA}{L}$$

### Flexural Stiffness

$$\text{Stiffness} = \frac{EI}{L}$$

# Deflection Limits (serviceability)

- Various guidelines have been derived, based on usage, to determine maximum allowable deflection limits.
- Typically, a floor system with a LL deflection in excess of L/360 will feel bouncy or crack plaster.
- Flat roofs require a minimum slope of 1/4" / ft to avoid ponding. "Ponding" refers to the retention of water due solely to deflection of relatively flat roofs. Progressive deflection due to progressively more impounded water can lead to collapse.



roof ponding  
from IRC, Josh 2014

**TABLE 1604.3  
DEFLECTION LIMITS<sup>a, b, c, h, i</sup>**

CONSTRUCTION	L	S or W <sup>f</sup>	D + L <sup>d, g</sup>
Roof members: <sup>c</sup>			
Supporting plaster ceiling	l/360	l/360	l/240
Supporting nonplaster ceiling	l/240	l/240	l/180
Not supporting ceiling	l/180	l/180	l/120
Floor members	l/360	—	l/240
Exterior walls and interior partitions:			
With brittle finishes	—	l/240	—
With flexible finishes	—	l/120	—
Farm buildings	—	—	l/180
Greenhouses	—	—	l/120

International Building Code - 2006

## Relationships of Forces and Deformations

There is a series of relationships involving forces and deformations along a beam, which can be useful in analysis. Using either the deflection or load as a starting point, the following characteristics can be discovered by taking successive derivatives or integrals of the beam equations.

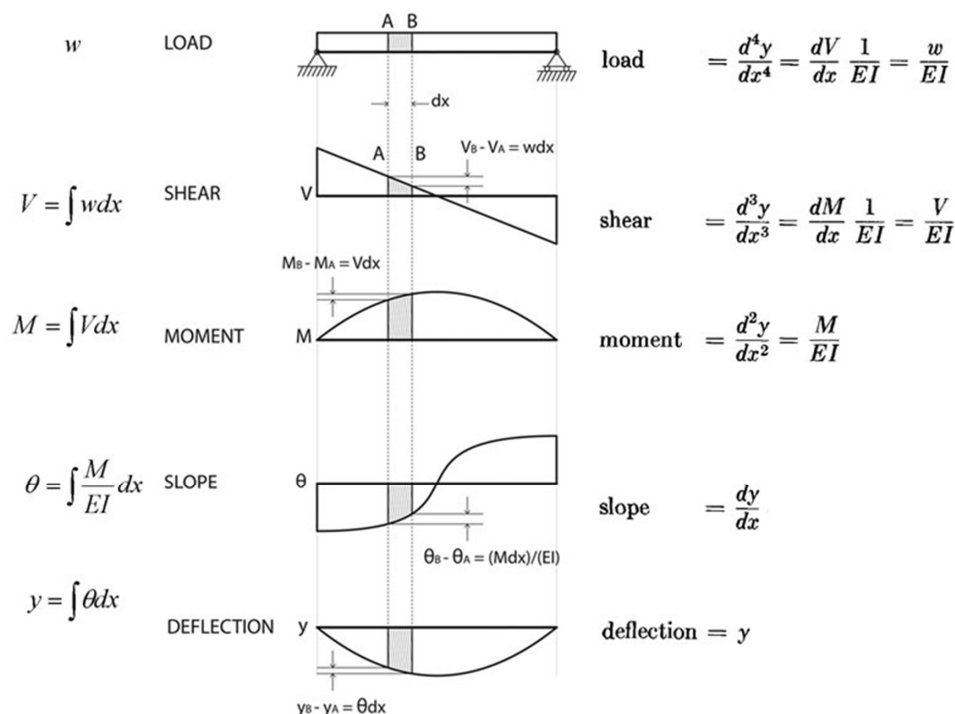

# Slope and Deflection in Symmetrically Loaded Beams

- **Maximum slope** occurs at the ends of the beam
- A point of zero slope occurs at the center line. This is the point of **maximum deflection**.
- **Moment is positive** for gravity loads.
- Shear and slope have **balanced** + and - areas.
- **Deflection is negative** for gravity loads.

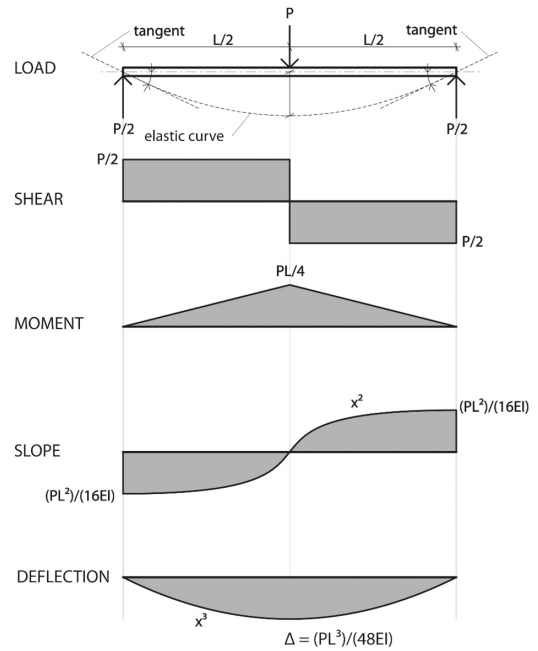

# Cantilever Beams

- One end fixed. One end free
- Fixed end has maximum moment, but zero slope and deflection.
- Free end has maximum slope and deflection, but zero moment.
- Slope is either downward (-) or upward (+) depending on which end is fixed.
- Shear sign also depends on which end is fixed.
- Moment is always negative for gravity loads.
- Deflection is always negative with maximum at the free end for gravity loads.

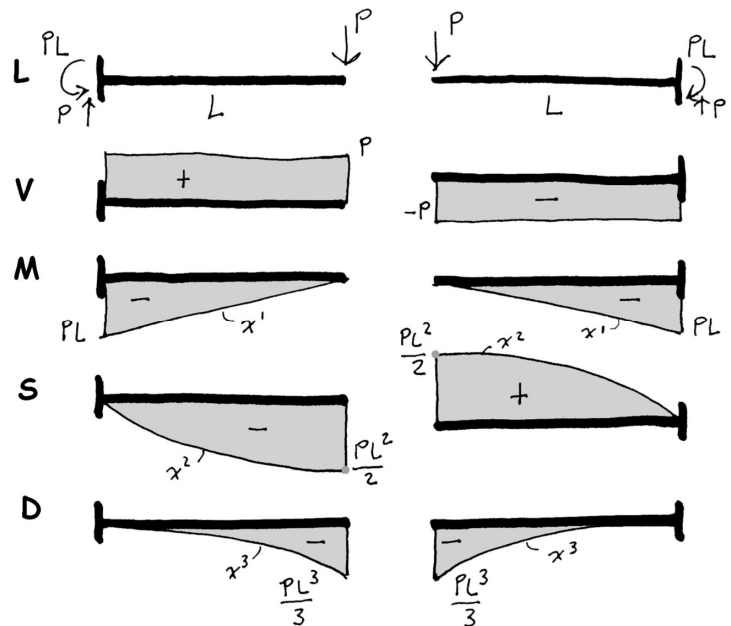

# Deflection Quiz

For the beam shown, the downward point load produces an upward deflection on the cantilever. Sketch each of the diagrams below to show the beam behavior for this case.

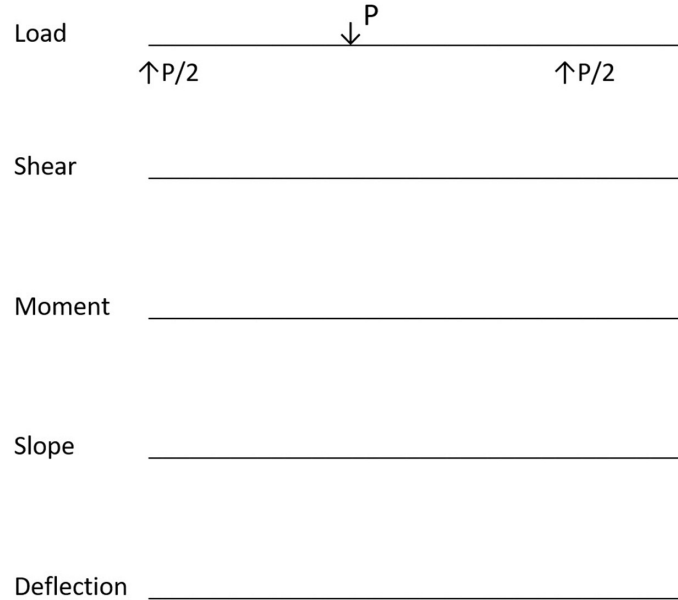

## Methods to Calculate Deflection

### Integration

can use to derive equations

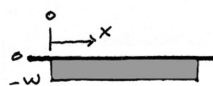
$$\int y \, dx = -w$$

### Diagrams

symmetric load cases

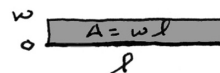
$$A = wl$$

### Diagrams (by parts)

asymmetric load cases



### Equations

single load cases

$$d = \frac{5wl^4}{384EI}$$

### Superposition of Equations

multiple load cases

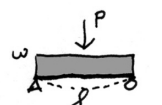
$$d = \frac{5wl^4}{384EI} + \frac{Pl^3}{48EI}$$

# Deflection by Integration

Load



$$y = -w$$

Shear

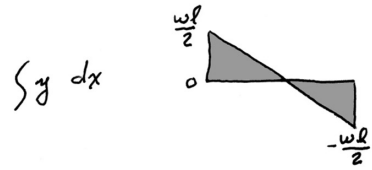

$$y = -wx + C$$

$$\text{@ } x = l/2 \quad y = 0$$

$$0 = -\frac{wl}{2} + C \therefore C = \frac{wl}{2}$$

$$\boxed{y = -wx + \frac{wl}{2}}$$

Moment

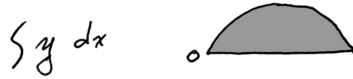

$$y = -\frac{wx^2}{2} + \frac{wlx}{2} + C$$

$$\text{@ } x = 0 \quad y = 0$$

$$0 = -0 + 0 + C \therefore C = 0$$

$$\boxed{y = -\frac{wx^2}{2} + \frac{wlx}{2}}$$

# Deflection by Integration

Slope

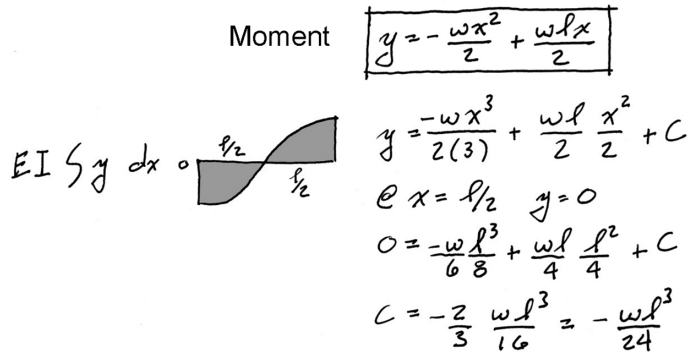

Moment

$$\boxed{y = -\frac{wx^2}{2} + \frac{wlx}{2}}$$

$$y = \frac{-wx^3}{2(3)} + \frac{wl}{2} \frac{x^2}{2} + C$$

$$\text{@ } x = l/2 \quad y = 0$$

$$0 = \frac{-wl^3}{6 \cdot 8} + \frac{wl}{4} \frac{l^2}{4} + C$$

$$C = -\frac{2}{3} \frac{wl^3}{16} = -\frac{wl^3}{24}$$

$$\boxed{y = \frac{-wx^3}{6} + \frac{wlx^2}{4} - \frac{wl^3}{24}}$$

Deflection



$$y = \frac{-wx^4}{24} + \frac{wlx^3}{12} - \frac{wl^3x}{24} + C$$

$$\text{@ } x = 0 \quad y = 0 \therefore C = 0$$

$$\text{@ } x = l/2 \quad (\text{max defl.})$$

$$y = \frac{-wl^4}{24(16)} + \frac{wl^4}{12(8)} - \frac{wl^4}{24(2)}$$

$$y = \frac{-\frac{1}{8}wl^4}{48} + \frac{\frac{1}{8}wl^4}{48} - \frac{\frac{1}{8}wl^4}{48}$$

$$y = -\frac{5}{8} \frac{wl^4}{48} = -\frac{5wl^4}{384}$$

# Deflection by Diagrams

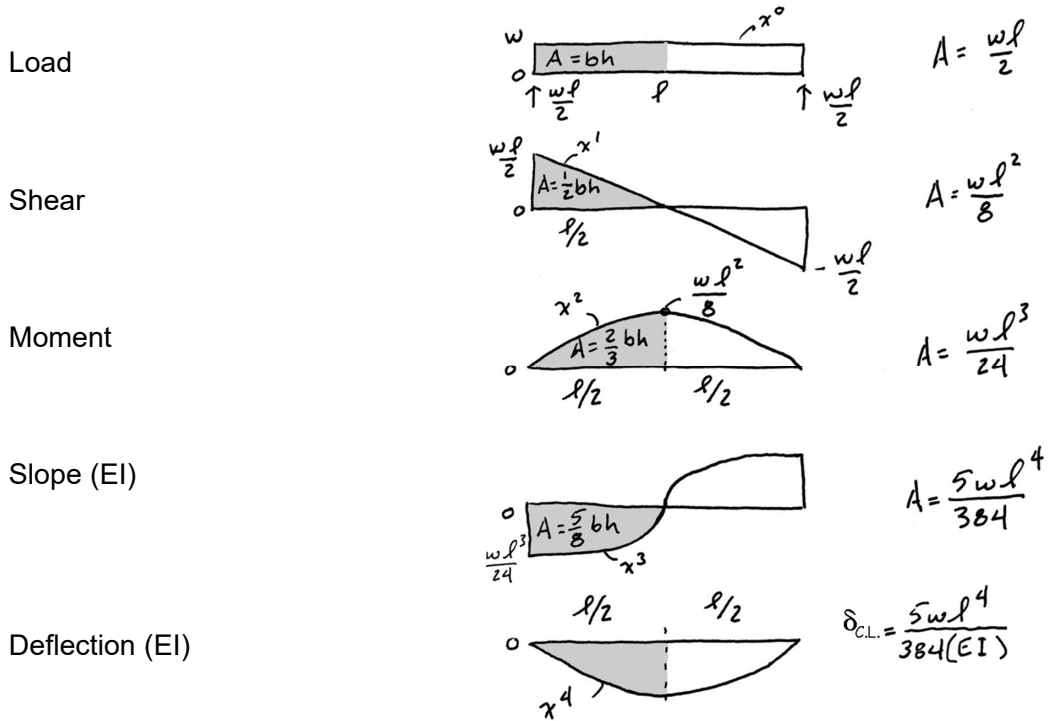
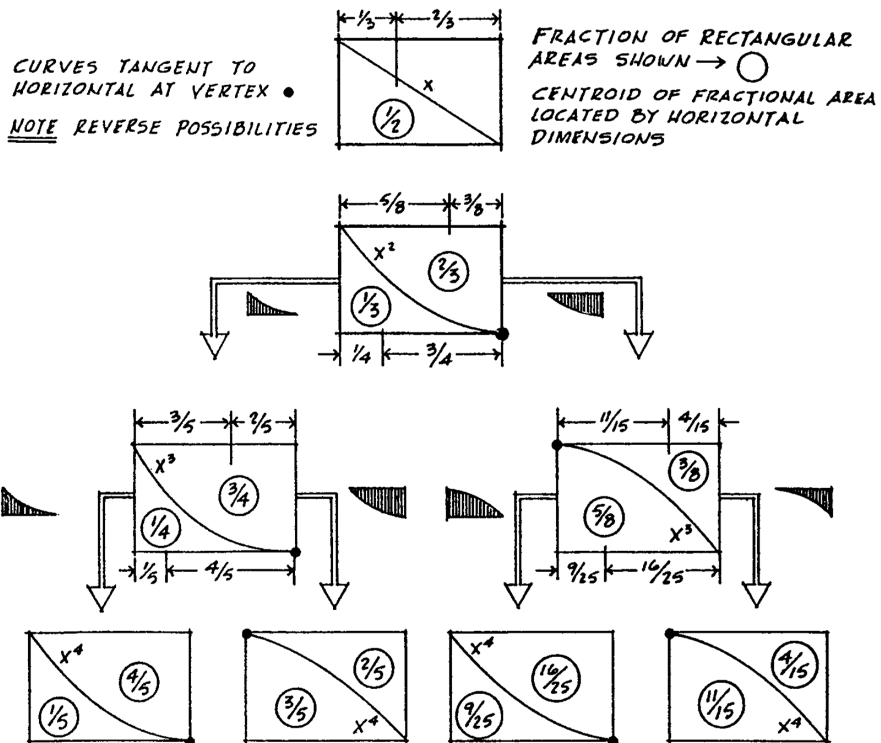

Table D-24 I. Engel

## FRACTIONAL AREAS OF ENCLOSURE RECTANGLES



# Deflection by Diagrams

example 1

BEAM: W16x36  
 $I = 448 \text{ IN}^4$   
 $E = 30 \times 10^3 \text{ K.S.I.}$

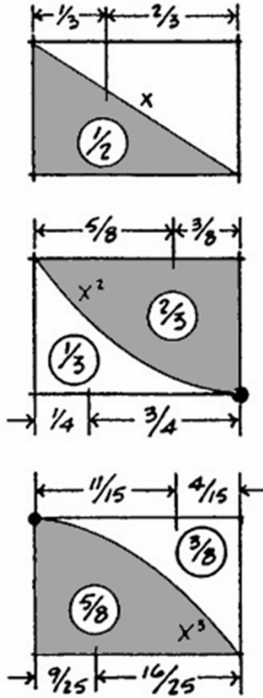

LOADING DIAGRAM

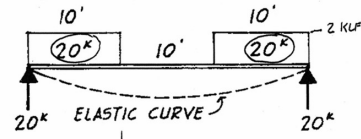

SHEAR DIAGRAM

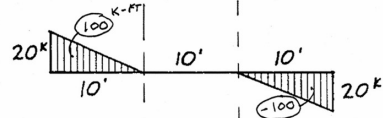

MOMENT DIAGRAM

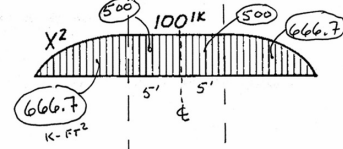

SLOPE DIAGRAM (EI)

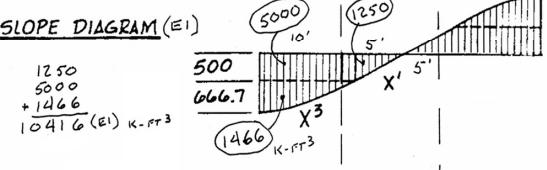

DEFLECTION DIAGRAM (EI)

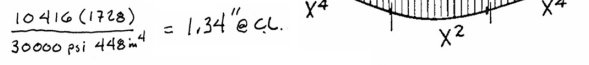

# Deflection by Diagrams

example 2

$E = 29000 \text{ ksi}$   
 $I = 400 \text{ in}^4$

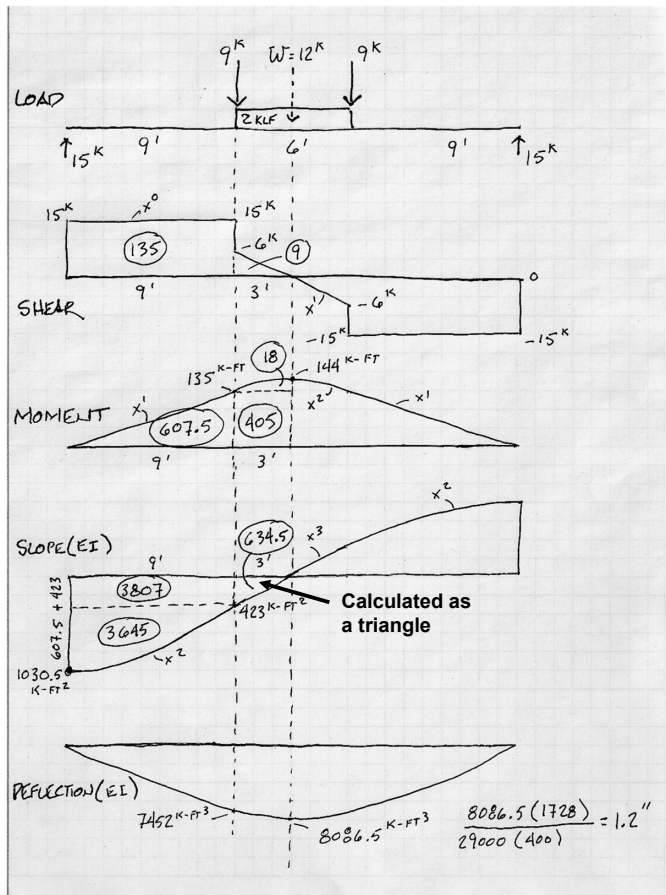
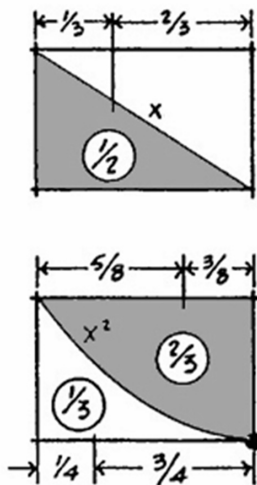



# Diagrams by Parts

● marks vertex which must be present for area equations to be valid.

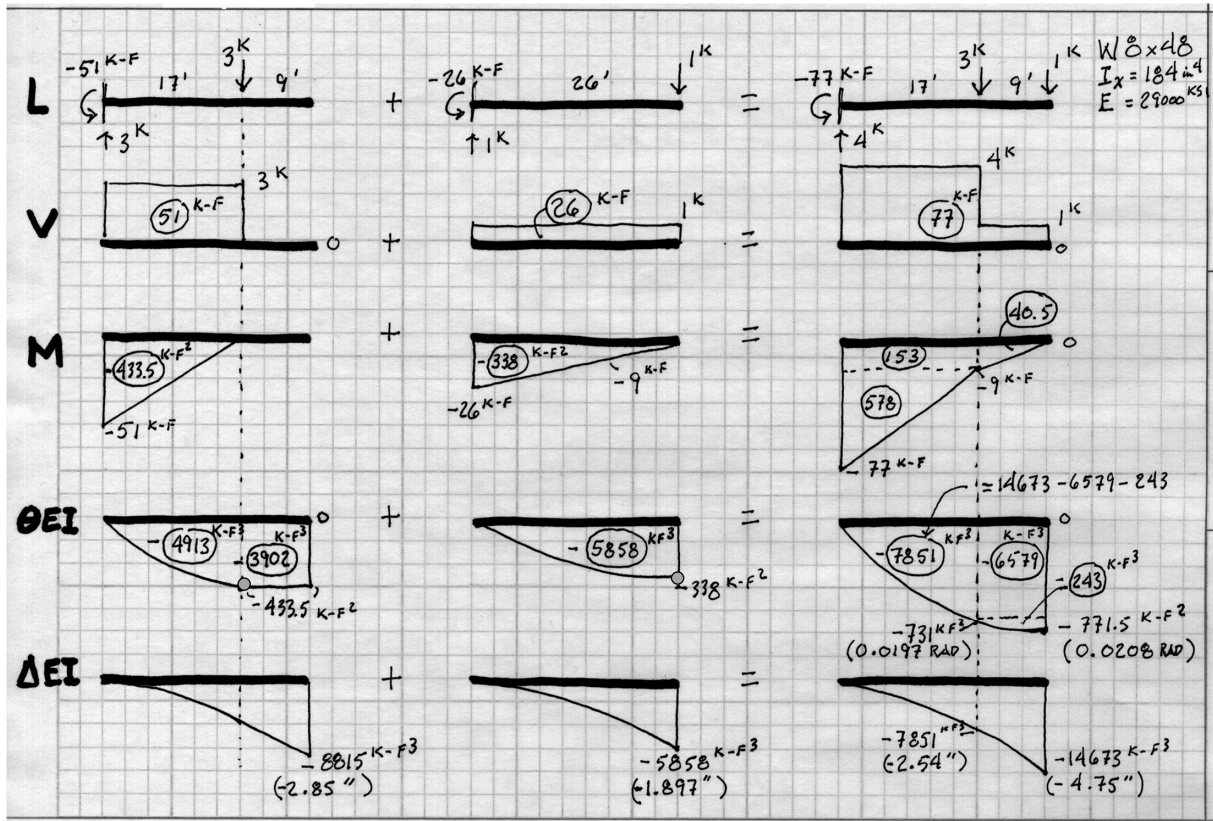

## Methods to Calculate Deflection

### Integration

can use to derive equations

$$\int y \, dx = \int -w \, dx$$

### Diagrams

symmetric load cases

$$A = wl$$

### Diagrams (by parts)

asymmetric load cases



### Equations

single load cases

$$d = \frac{5wl^4}{384EI}$$

### Superposition of Equations

multiple load cases

$$d = \frac{5wl^4}{384EI} + \frac{Pl^3}{48EI}$$

## Deflection: by Equations

- Deflection can be determined by the use of equations for specific loading conditions.
- See posted pages for more equations. A good source is the **AISC Steel Manual**.
- By “**superposition**” equations can be added for combination load cases. Care should be taken that added equations all give deflection **at the same point**, e.g. the center line.
- Note that if beam lengths and load ( $w$ ) are entered in feet, a conversion factor of **1728** in<sup>3</sup>/ft<sup>3</sup> must be applied in order to compute deflection in inches.

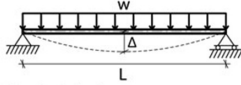
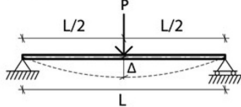
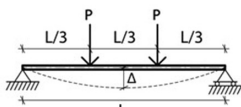
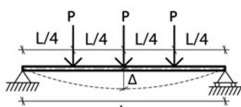
Beam Load and Support	Actual Deflection
 <p>(a) Uniform load, simple span</p>	$\Delta_{\max} = \frac{5\omega L^4}{384EI}$ <p>(at the centerline)</p>
 <p>(b) Concentrated load at midspan</p>	$\Delta_{\max} = \frac{PL^3}{48EI}$ <p>(at the centerline)</p>
 <p>(c) Two equal concentrated loads at third points</p>	$\Delta_{\max} = \frac{23PL^3}{648EI} = \frac{PL^3}{28.2EI}$ <p>(at the centerline)</p>
 <p>(d) Three equal concentrated loads at quarter points</p>	$\Delta_{\max} = \frac{PL^3}{20.1EI}$ <p>(at the centerline)</p>

## Example: Equations Method – By Superposition

- To determine the total deflection of the beam for the given loading condition, begin by breaking up the loading diagram into parts, one part for each load case.
- Compute the total deflection by **superposing** the deflections from each of the individual loading conditions. In this example, use the equation for a mid-span point load and the equation for a uniform distributed load.

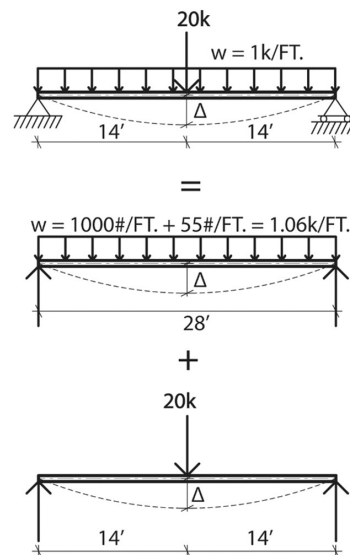

$$\Delta_{\text{actual}} = \frac{PL^3}{48EI} + \frac{5\omega L^4}{384EI}$$

## Example: Equations Method

- For a **W18x55** with an
  - E modulus of 30000 ksi
  - moment of inertia of 890 in<sup>4</sup>
- Using an allowable deflection limit of **L / 240**.
- Check deflection

$$\Delta_{\text{actual}} = \frac{PL^3}{48EI} + \frac{5\omega L^4}{384EI}$$

$$\Delta_{\text{actual}} = \frac{20 \text{ k}(28')^3}{48(30 \times 10^3)(890)} + \frac{5(1.06 \text{ k/ft.})(28')^4}{(384)(30 \times 10^3)(890)}$$

$$\Delta_{\text{actual}} = 0.59'' + 0.55'' = 1.14''$$

$$\Delta_{\text{allow}} = \frac{L}{240} = \frac{28' \times 12 \text{ in./ft.}}{240} = 1.4''$$

$$\Delta_{\text{actual}} = 1.14'' < 1.4'' \therefore \text{OK}$$

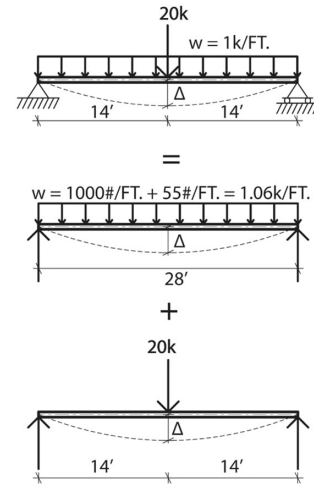

## Example: Asymmetrical Loading – Superposition of Equations

Standard equations provide values of shear, moment and deflection at points along a beam.

Cases can be **superposed** or overlaid to obtain combined values at some point on the beam.

### 5. SIMPLE BEAM—UNIFORM LOAD PARTIALLY DISTRIBUTED AT ONE END

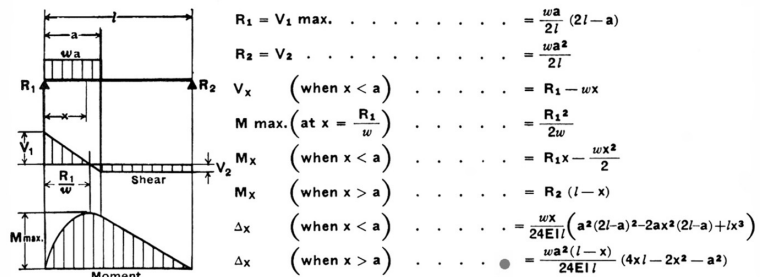

To find the point of combined maximum deflection, the derivative of the combined deflection equation can be solved for 0. This gives the point with slope = 0 which is a max/min on the deflection curve.

### 8. SIMPLE BEAM—CONCENTRATED LOAD AT ANY POINT

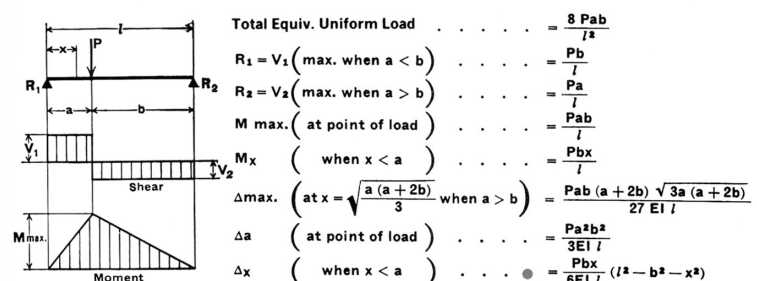

## Example (same equations as above): Asymmetrical Loading – Superposition

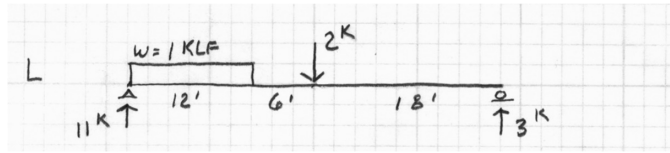

Deflection equations for cases 5 + 8

Input actual dimensions

Reduce and write deflection equation in terms of x

Differentiate dy/dx to get the slope equation

Set slope equation = 0

Solve for x

This will be the point of  $\Delta_{max}$

USING SUPERPOSITION OF CASE 5 + CASE 8

$$\Delta_{@x} = \text{CASE 5} + \text{CASE 8}$$

$$\Delta = \frac{w\bar{a}^2(l-x)(4xl-2x^2-\bar{a}^2)}{24EIl} + \frac{Pbx}{6EIl}(l^2-b^2-x^2)$$

$$EI\Delta = \frac{1(12^2)(36-x)(4x36-2x^2-12^2)}{24(36)} + \frac{2(18)x}{6(36)}(36^2-18^2-x^2)$$

$$= (6 - \frac{x}{6})(144x - 2x^2 - 144) + \frac{x}{6}(972 - x^2)$$

$$= \frac{x^3}{6} - 36x^2 + 1050x - 864$$

$$f'(x) = \frac{x^2}{2} - 72x + 1050$$

THIS IS THE EQUATION FOR SLOPE FOR  $12 < x < 18$  WHERE SLOPE = 0,  $\Delta = \Delta_{max}$

$$0 = \frac{x^2}{2} - 72x + 1050$$

$$x = \frac{144 \pm 4\sqrt{771}}{2}$$

$$\begin{aligned} x &= 127.5 \\ x &= 16.4662' \end{aligned}$$

## Example (same as above): Asymmetrical Loading – Superposition

Deflection equations (5 + 8)

Input beam distances as before and reduce terms

Solve deflection for  $x=16.5'$

Solve for specific section and material by dividing by EI of the section

$$\Delta_{\text{cases 5\&8}} = \frac{w\bar{a}^2(l-x)(4xl-2x^2-\bar{a}^2)}{24EIl} + \frac{Pbx}{6EIl}(l^2-b^2-x^2)$$

$$\Delta(EI) = \frac{x^3}{6} - 36x^2 + 1050x - 864$$

$$\Delta(EI) = \frac{16.5^3}{6} - 36(16.5)^2 + 1050(16.5) - 864$$

$$= 748.6 - 9801 + 17325 - 864$$

$$= 7408 \text{ K-FT}^3$$

FOR W 12x26

$$I = 204 \text{ in}^4$$

$$E = 29000 \text{ KSI}$$

$$\Delta_{max} = \frac{7408 (1728)}{29000 (204)}$$

$$= 2.16''$$

$$= 2.16''$$

# Estimate: Asymmetrical Loading – Superposition of Equations

Or as an estimate...

It is also possible to **estimate** the deflection location and value without the more exact calculation of  $x$ .

If an equation for  $\Delta$  max is given, use that (conservative).

Otherwise guess  $x$  near mid-span.

for example in this case

using C.L. = 18 ft

$\Delta = 7344 \text{ k-ft}^3 = 2.15''$

0.46 % off

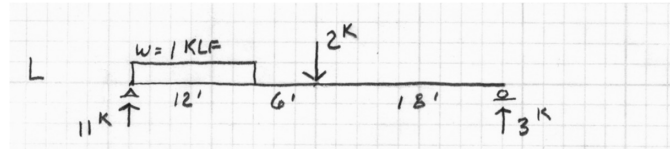

## 5. SIMPLE BEAM—UNIFORM LOAD PARTIALLY DISTRIBUTED AT ONE END

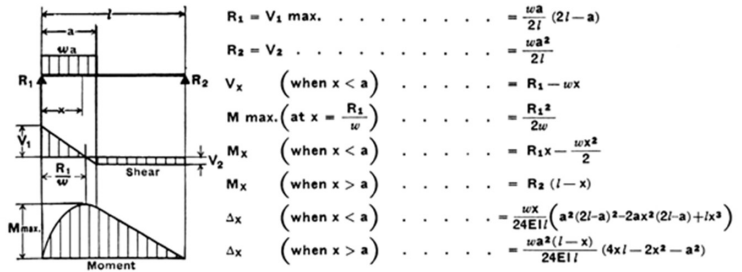

## 8. SIMPLE BEAM—CONCENTRATED LOAD AT ANY POINT

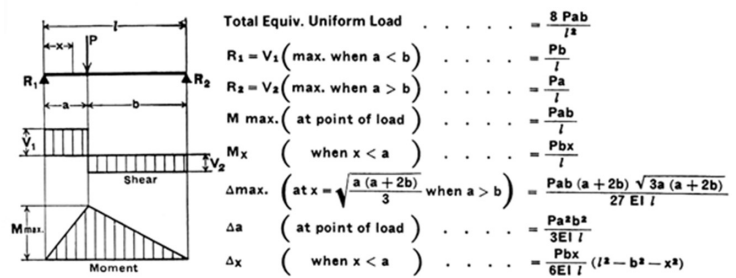

Steel Construction Manual  
AISC 1989