

Arch 314- Structures I

Recitation 006



Vishakha Bagarao

22nd Nov 2024

Contents

- Quick Recap
 - Shear and Bending stresses
 - Problem Set 13- Horizontal Shear
- Lab 11- Shear Stress

Final Bridge Report:

- Due- 25th Nov

NOV 15	Recitation 10. Moment Diagrams Topic Quiz 12	Ch. 8.1-8.2: pp. 365-381 12. V & M Diagrams (11.17)
NOV 18	Bending Stresses	Ch. 8.1-8.2: pp. 365-381
NOV 20	Shear Stresses	Ch. 8.1-8.2: pp. 365-381
NOV 22	Recitation 11. Shear Stress Topic Quiz 13	13. Horizontal Shear (11.24)
NOV 25	video "When Engineering Fails"	(final bridge report due - 11.25)
NOV 27	***** THANKSGIVING RECESS *****	***** THANKSGIVING RECESS *****







- [Link](#) to bridge report examples

FINAL REPORT REQUIREMENTS		150
Preliminary Design Development		20
How initial (preliminary) bridge design was developed	4	
How initial (preliminary) member sizes were chosen	4	
Why bridge design was or was not adjusted from preliminary design	4	
Why member sizes were or were not adjusted from preliminary design	4	
Discussion of how pre-analysis of initial bridge impacted the final design	4	
Revised Bridge Design Analysis		50
Internal axial force calculations/modeling (with proper design loading indicated) (Dr. Frame acceptable)	10	
Derivation of member cross-sectional areas from axial forces	10	
Member size selection from available stock	4	
Est. weight calculation of bridge - including members, glue & fasteners	6	
Method of joints/sections calculation for at least 1 joint (@ reaction is usually easiest based on truss geometry, but could be done elsewhere)	10	
Member crushing calculations/check (show work) using $F'_c = P/A$	4	
Prediction of capacity of bridge and mode of failure	6	
Illustration of Tested (Revised from Preliminary) Design		20
Cross-section of bridge	4	
Elevation(s) of bridge	4	
Dimensions and units labeled in elevation and cross-section	4	
Member sizes labeled (with dimensions)	4	
Member stresses labeled (with units)	4	
Testing Results		30
Weight and height of bridge	5	
Capacity of bridge	5	
Observations of testing	6	
Description of mode of failure	5	
Images of failure	5	
Following the guidelines	4	
Post-Testing Analysis		30
Comparison of testing with predicted capacity and modes of failure	10	
Discussion of discrepancies between results	10	
Suggested improvements for future designs with reasoning discussed	10	
FINAL GRADE	250	

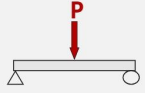
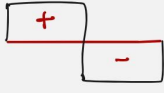
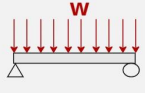
Load and Shear Diagrams:

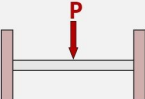
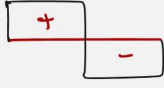
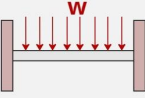
General considerations for drawing shear diagrams:

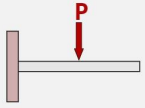
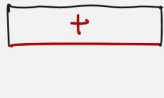
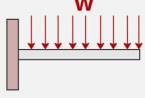
- When all loads and reactions are known, the shear at the ends of the beam can be determined by inspection.
 - **At a simply supported or pinned end, the shear must equal the end reaction.**
 - **Shear are zero at a free end of a beam (cantilever beam or overhang beam).**
 - **At a built-in or fixed-end beam, the reactions are equal to the shear values.**
- When positive directions are chosen as upward and to the right, a uniformly distributed load acting downward will give a negative slope in the shear diagram, and a positive distributed load (one acting upward) will result in a positive slope.
- A concentrated force produces an abrupt change in shear.
- The change in shear between any two sections is given by the area under the load diagram between the same two sections.
- The change of shear at a concentrated force is equal to the concentrated force.

Beams with Loadings	SFD
Simply Supported beam with Point load: 	
Simply Supported beam with uniformly distributed load: 	
Fixed beam with Point load: 	
Fixed beam with uniformly distributed load: 	
Cantilever beam with Point load: 	
Cantilever beam with uniformly distributed load: 	

Formulas:

- Step 1: Beam Reaction R_1 and R_2

$$\sum M = 0$$

$$\sum V = 0$$

- Step 2: Shear Values: V

Draw a shear diagram

- Step 3: Static Moment : Q

$$Q = \sum \text{Area}(A) \times \text{distance}(\bar{y})$$

- Step 4: Moment of Inertia: I

$$I = \sum I_{xx} + \sum I_2$$

- Step 5: Horizontal shear stresses: τ

$$\tau = \frac{V_{\max} \times Q}{I \times b}$$

The static Moment (Q) measures the distribution of a beam section's area relative to an axis

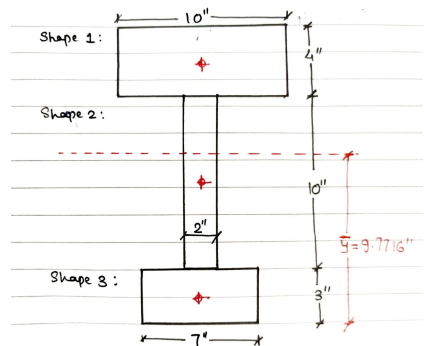
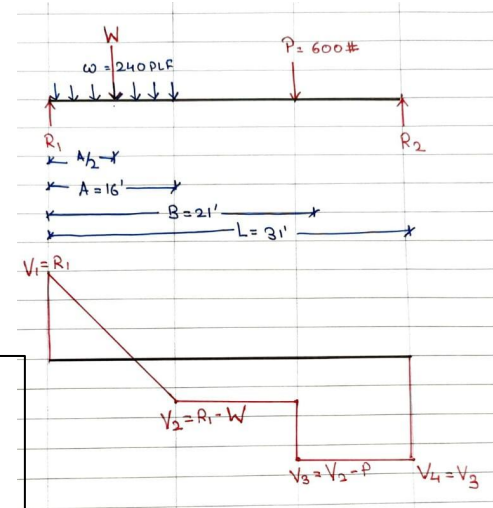

Problem Set 13

Logged in as: Vishakha Bagarao

13. Horizontal Shear

Determine the maximum overall shear force and the horizontal shear stress at that location. Then find the horizontal shear stress at each end of the center web (top and bottom).

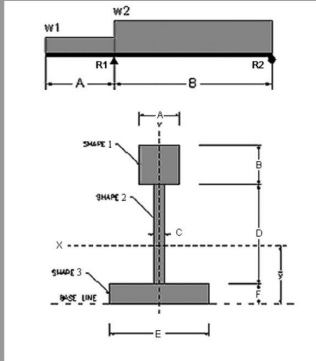

DATASET: 2 +1 -3

Section dimension A	10 IN
Section dimension B	4 IN
Section dimension C	2 IN
Section dimension D	10 IN
Section dimension E	7 IN
Section dimension F	3 IN
Beam span A	12 FT
Beam span B	11 FT
Beam load w1	29 PLF
Beam load w2	48 PLF

#	Question	Your Response	Correct Answer	Score
1	Beam reaction R1 (upward is +)	801.818 LBS	801.818 LBS	5
2	Beam reaction R2 (upward is +)	74.1818 LBS	74.1818 LBS	5
3	Negative shear at R1 (use - sign)	-348 LBS	-348 LBS	5
4	Positive shear at R1	453.818 LBS	453.818 LBS	5
5	Shear at R2 (use - or + sign)	-74.1818 LBS	-74.1818 LBS	5
6	Maximum shear force (absolute value)	453.818 LBS	453.818 LBS	5
7	Static Moment (Q) at top of shape 2	209.136 IN^3	209.136 IN^3	5
8	Static Moment (Q) at bottom of shape 2	173.704 IN^3	173.704 IN^3	5
9	Static Moment (Q) at the neutral axis	219.559 IN^3	219.559 IN^3	5
10	Moment of Inertia about the neutral axis	2828.77 IN^4	2828.77 IN^4	5
11	Section width at the neutral axis	2 IN	2 IN	5
12	Horizontal shear stress at the top of shape 2 for Vmax	16.7758 PSI	16.7757 PSI	5
13	Horizontal shear stress at the bottom of shape 2 for Vmax	13.931 PSI	13.9336 PSI	5
14	Horizontal shear stress at the neutral axis for Vmax	17.6086 PSI	17.6118 PSI	5

Current Score: 70/70

[Problem Menu](#)

[Logout](#)

Horizontal Shear.

Step I: ~~Find~~ Reactions:

#1, #2. Beam reaction R1; Beam reaction R2
(+ is upward; - is downward).

$$W_1 = w_1 \times \text{span A} = 29 \times 12 = 348 \text{ LBS.}$$

$$W_2 = w_2 \times \text{span B} = 48 \times 11 = 528 \text{ LBS.}$$

$$\sum M @ R_1 = -W_1 \times \frac{\text{span A}}{2} + W_2 \times \frac{\text{span B}}{2} - R_2 \times \text{span B} = 0$$

$$0 = -348 \times 12/2 + 528 \times 11/2 - R_2 \times 11$$

$$11R_2 = 816$$

$$\therefore R_2 = 816/11$$

$$\therefore R_2 = 74.1818 \text{ LBS.}$$

$$\sum V = -W_1 + R_1 - W_2 + R_2 = 0$$

$$0 = -348 + R_1 - 528 + 74.1818$$

$$\therefore R_1 = 801.8181 \text{ LBS.}$$

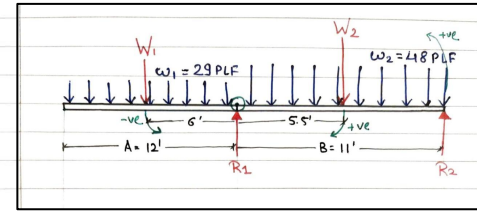

Step II: Shear values.

#3. Negative shear at R1 (Use - sign): V_2

Since, span A is cantilever, shear value will be 0 at cantilever end. The uniformly distributed load w_1 will push the shear down beam downwards.

$$V_2 = -W_1$$

$$\therefore V_2 = -348 \text{ LBS}$$

Problem Set 13

13. Horizontal Shear

Determine the maximum overall shear force and the horizontal shear stress at that location. Then find the horizontal shear stress at each end of the center web (top and bottom).

DATASET: 2 +1 -3

Section dimension A	10 IN
Section dimension B	4 IN
Section dimension C	2 IN
Section dimension D	10 IN
Section dimension E	7 IN
Section dimension F	3 IN
Beam span A	12 FT
Beam span B	11 FT
Beam load w1	29 PLF
Beam load w2	48 PLF

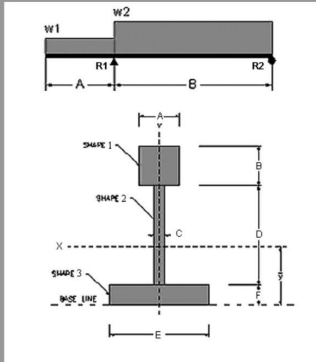

#	Question	Your Response	Correct Answer	Score
1	Beam reaction R1 (upward is +)	801.818 LBS	801.818 LBS	5
2	Beam reaction R2 (upward is +)	74.1818 LBS	74.1818 LBS	5
3	Negative shear at R1 (use - sign)	-348 LBS	-348 LBS	5
4	Positive shear at R1	453.818 LBS	453.818 LBS	5
5	Shear at R2 (use - or + sign)	-74.1818 LBS	-74.1818 LBS	5
6	Maximum shear force (absolute value)	453.818 LBS	453.818 LBS	5
7	Static Moment (Q) at top of shape 2	209.136 IN^3	209.136 IN^3	5
8	Static Moment (Q) at bottom of shape 2	173.704 IN^3	173.704 IN^3	5
9	Static Moment (Q) at the neutral axis	219.559 IN^3	219.558 IN^3	5
10	Moment of Inertia about the neutral axis	2828.77 IN^4	2828.77 IN^4	5
11	Section width at the neutral axis	2 IN	2 IN	5
12	Horizontal shear stress at the top of shape 2 for Vmax	16.7758 PSI	16.7757 PSI	5
13	Horizontal shear stress at the bottom of shape 2 for Vmax	13.931 PSI	13.9336 PSI	5
14	Horizontal shear stress at the neutral axis for Vmax	17.6086 PSI	17.6118 PSI	5

Current Score: 70 / 70

[Problem Menu](#)

[Logout](#)

#4. Positive shear at R1 : V3.

R1 will exert an abrupt upward force.

$$V_3 = V_2 + R_1$$

$$= -348 + 801.818$$

$$\therefore V_3 = 453.818 \text{ LBS}$$

#5. Shear at R2 : V4

The uniformly distributed force w2 will gradually push beam downwards.

$$V_4 = V_3 - W_2$$

$$= 453.818 - 528$$

$$\therefore V_4 = -74.1818 \text{ LBS}$$



#6. Maximum shear force (absolute value): Vmax.

$$V_{max} = V_3$$

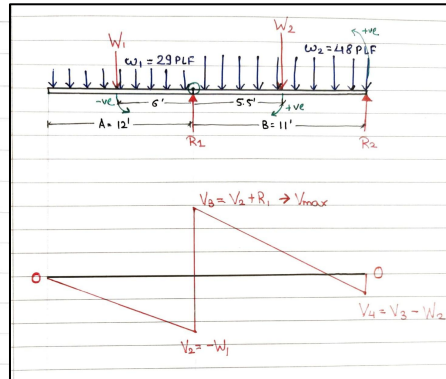
$$\therefore V_{max} = 453.818 \text{ LBS}$$

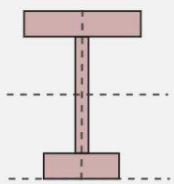

Problem Set 13

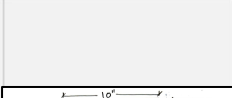
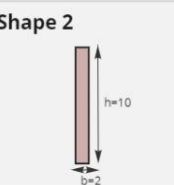
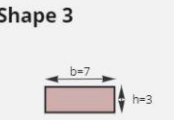
	Area ($A=b \times h$)	Distance (d)	Area x Distance (Ad)		$I_{xx} = \frac{1}{12} \times b \times h^3$	dc = d-y	$I_2 = A \times dc^2$	Parallel Axis Theorem		
Shape 1 	$10 \times 4 = 40$	$B/2 + D + F = 15$	$Ad_1 = A \times d$ $= 40 \times 15$ $= 600$	$y = \frac{\sum Ad}{\sum A}$	$I_{xx} = \frac{10 \times 4^3}{12}$ $= 53.3333$	$dc = 15 - 9.7716 $ $= 5.2284$	$I_2 = 40 \times 5.2284^2$ $= 1093.445$			
Shape 2 	$2 \times 10 = 20$	$D/2 + F = 8$	$Ad_2 = A \times d$ $= 20 \times 8$ $= 160$		$y = 791.5 / 81$ $y = 9.7716$	$I_{xx} = \frac{2 \times 10^3}{12}$ $= 166.6667$	$dc = 8 - 9.7716 $ $= 1.7716$		$I_2 = 20 \times 1.7716^2$ $= 62.7717$	$I = \sum I_{xx} + \sum I_2$ $= 235.75 + 2593.0247$ $= 2828.77$
Shape 3 	$7 \times 3 = 21$	$F/2 = 1.5$	$Ad_3 = A \times d$ $= 21 \times 1.5$ $= 31.5$			$I_{xx} = \frac{7 \times 3^3}{12}$ $= 15.75$	$dc = 0.5 - 9.7716 $ $= 8.276$		$I_2 = 21 \times 8.276^2$ $= 1436.8084$	
	$\sum A = 40 + 20 + 21 = 81$	Note: Refer Problem Set and diagram for dimensions A, B, C, D, E, and F.	$\sum Ad = 600 + 160 + 31.5 = 791.5$		$\sum I_{xx} = 235.75$		$\sum I_2 = 2593.0247$			

Problem Set 13

13. Horizontal Shear

Determine the maximum overall shear force and the horizontal shear stress at that location. Then find the horizontal shear stress at each end of the center web (top and bottom).

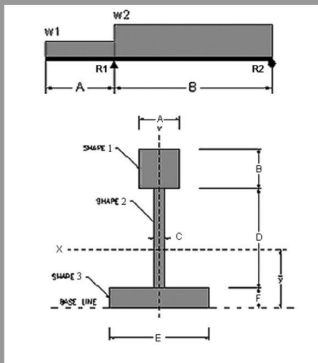

DATASET: 2 +1 -3

Section dimension A	10 IN
Section dimension B	4 IN
Section dimension C	2 IN
Section dimension D	10 IN
Section dimension E	7 IN
Section dimension F	3 IN
Beam span A	12 FT
Beam span B	11 FT
Beam load w1	29 PLF
Beam load w2	48 PLF

#	Question	Your Response	Correct Answer	Score
1	Beam reaction R1 (upward is +)	801.818 LBS	801.818 LBS	5
2	Beam reaction R2 (upward is +)	74.1818 LBS	74.1818 LBS	5
3	Negative shear at R1 (use - sign)	-348 LBS	-348 LBS	5
4	Positive shear at R1	453.818 LBS	453.818 LBS	5
5	Shear at R2 (use - or + sign)	-74.1818 LBS	-74.1818 LBS	5
6	Maximum shear force (absolute value)	453.818 LBS	453.818 LBS	5
7	Static Moment (Q) at top of shape 2	209.136 IN ³	209.136 IN ³	5
8	Static Moment (Q) at bottom of shape 2	173.704 IN ³	173.704 IN ³	5
9	Static Moment (Q) at the neutral axis	219.559 IN ³	219.559 IN ³	5
10	Moment of Inertia about the neutral axis	2828.77 IN ⁴	2828.77 IN ⁴	5
11	Section width at the neutral axis	2 IN	2 IN	5
12	Horizontal shear stress at the top of shape 2 for V _{max}	16.7758 PSI	16.7757 PSI	5
13	Horizontal shear stress at the bottom of shape 2 for V _{max}	13.931 PSI	13.9336 PSI	5
14	Horizontal shear stress at the neutral axis for V _{max}	17.6086 PSI	17.6118 PSI	5

Current Score: 70 / 70

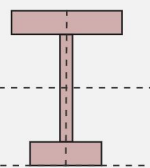

Area (A=b x h)

y' = difference between center of the shape to the neutral axis

$$Q = \sum \text{Area}(A) \times \text{distance}(\bar{y})$$

Q at the top of shape 2

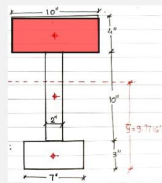

$$10 \times 4 = 40$$

$$y' = |15 - 9.7716| = 5.2284$$

$$Q_t = 40 \times 5.2284 = 209.136$$

Q at the bottom of shape 2

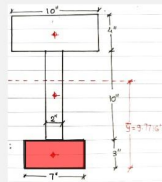

$$7 \times 3 = 21$$

$$y' = |9.7716 - 3/2| = 8.2716$$

$$Q_b = 21 \times 8.2716 = 173.7036$$

Q at the neutral axis

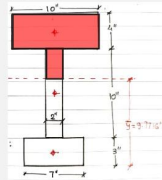

$$\begin{aligned} A1: 10 \times 4 &= 40 \\ A2: 2 \times (13 - 9.7716) &= 2 \times 3.2284 \\ &= 6.4568 \end{aligned}$$

$$\begin{aligned} y' &= |15 - 9.7716| = 5.2284 \\ y' &= |3.2284/2| = 1.6142 \end{aligned}$$

$$\begin{aligned} Q_n &= Q_t + Q_s \\ &= 209.136 + (6.4568 \times 1.6142) \\ &= 219.559 \end{aligned}$$

Problem Set 13

Logged in as: Vishakha Bagarao

13. Horizontal Shear

Determine the maximum overall shear force and the horizontal shear stress at that location. Then find the horizontal shear stress at each end of the center web (top and bottom).

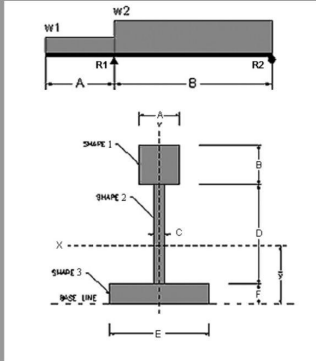

DATASET: 2 +1 -3

Section dimension A	10 IN
Section dimension B	4 IN
Section dimension C	2 IN
Section dimension D	10 IN
Section dimension E	7 IN
Section dimension F	3 IN
Beam span A	12 FT
Beam span B	11 FT
Beam load w1	29 PLF
Beam load w2	48 PLF

#	Question	Your Response	Correct Answer	Score
1	Beam reaction R1 (upward is +)	801.818 LBS	801.818 LBS	5
2	Beam reaction R2 (upward is +)	74.1818 LBS	74.1818 LBS	5
3	Negative shear at R1 (use - sign)	-348 LBS	-348 LBS	5
4	Positive shear at R1	453.818 LBS	453.818 LBS	5
5	Shear at R2 (use - or + sign)	-74.1818 LBS	-74.1818 LBS	5
6	Maximum shear force (absolute value)	453.818 LBS	453.818 LBS	5
7	Static Moment (Q) at top of shape 2	209.136 IN ³	209.136 IN ³	5
8	Static Moment (Q) at bottom of shape 2	173.704 IN ³	173.704 IN ³	5
9	Static Moment (Q) at the neutral axis	219.559 IN ³	219.558 IN ³	5
10	Moment of Inertia about the neutral axis	2828.77 IN ⁴	2828.77 IN ⁴	5
11	Section width at the neutral axis	2 IN	2 IN	5
12	Horizontal shear stress at the top of shape 2 for Vmax	16.7758 PSI	16.7757 PSI	5
13	Horizontal shear stress at the bottom of shape 2 for Vmax	13.931 PSI	13.9336 PSI	5
14	Horizontal shear stress at the neutral axis for Vmax	17.6086 PSI	17.6118 PSI	5

Current Score: 70/70

[Problem Menu](#)

[Logout](#)

Step V: Horizontal shear stress for Vmax.

$$\tau = \frac{VQ}{I \cdot b} = \frac{V_{max} \cdot Q}{I \cdot b}$$

$$= \frac{458.818 \times Q}{2828.77 \times 2}$$

$$\therefore \tau = 0.0802 \times Q$$

#12. Horizontal shear stress at the top of shape 2 for Vmax : τ_t

$$\tau_t = 0.0802 \times Q_t$$

$$= 0.0802 \times 209.136$$

$$\therefore \tau_t = 16.7758 \text{ PSI}$$

#13. Horizontal shear stress at the bottom of shape 2 for Vmax : τ_b

$$\tau_b = 0.0802 \times Q_b$$

$$= 0.0802 \times 173.7036$$

$$\therefore \tau_b = 13.931 \text{ PSI}$$

#14. Horizontal shear stress at the neutral axis of shape 2 for Vmax : τ_n

$$\tau_n = 0.0802 \times Q_n$$

$$= 0.0802 \times 219.554$$

$$\therefore \tau_n = 17.6086 \text{ PSI}$$

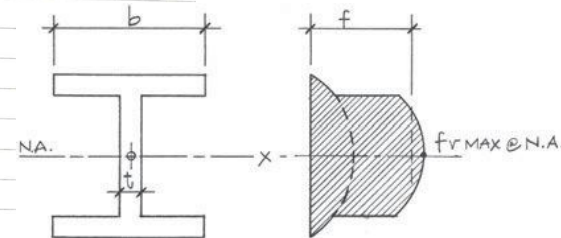
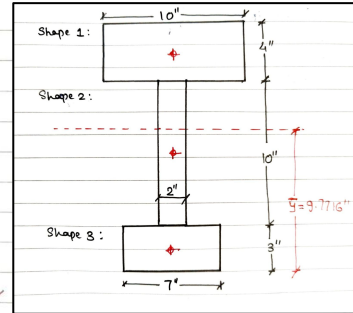

Lab 11 Shear Stresses

Structures I

Arch 314

Name 1 _____

Name 2 _____

Name 3 _____

Horizontal Shear Stress

Description

This project examines horizontal shear in a simple beam.

Goals

- To observe an example of shear force in an element.
- To gage the effect of shear stiffness.
- To observe horizontal shear failure.

Procedure

1. Place the clips at each end of the beam and position it on the supports.
2. Add the washer weight and measure the deflection.
3. Remove the clips and repeat the loading and again measure the deflection.
4. Note the slippage of the planes particularly at each end.
5. Compare the deflections of the two tests.

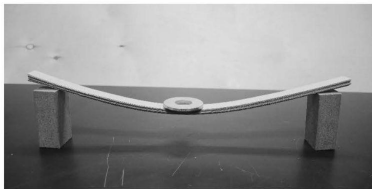
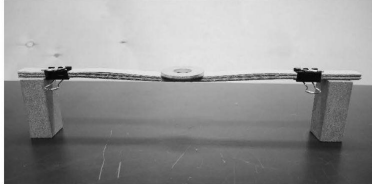

Due

During recitation