

Arch314

STRUCTURES I

Fall 2025
Recitation

FACULTY: Prof. Peter von Bülow
Mohsen Vatandoost

Arch314: STRUCTURES I

Welcome to Recitation session 11/15

Mohsen Vatandoost {Ph.D., M.Sc., M. Arch}

mohsenv@umich.edu

Office: Room 3128

hours:

Wed: 11:30 – 12:30

Mon, Fri: 11:30 - 13:00

walk-ins welcome!

Please feel free to ask questions.

Arch314: STRUCTURES I

Welcome to Recitation session 11/15

Outline:

- Quick **Recap** of the week
- Provide the solution for the assignment (**Homework 12**)
- Answering student's questions
- Lab: **Moment Diagrams**
- **Bridge** project (How to prepare the **Final Report**)

Please feel free to ask questions.

Recap of the week

Integral

Derivation

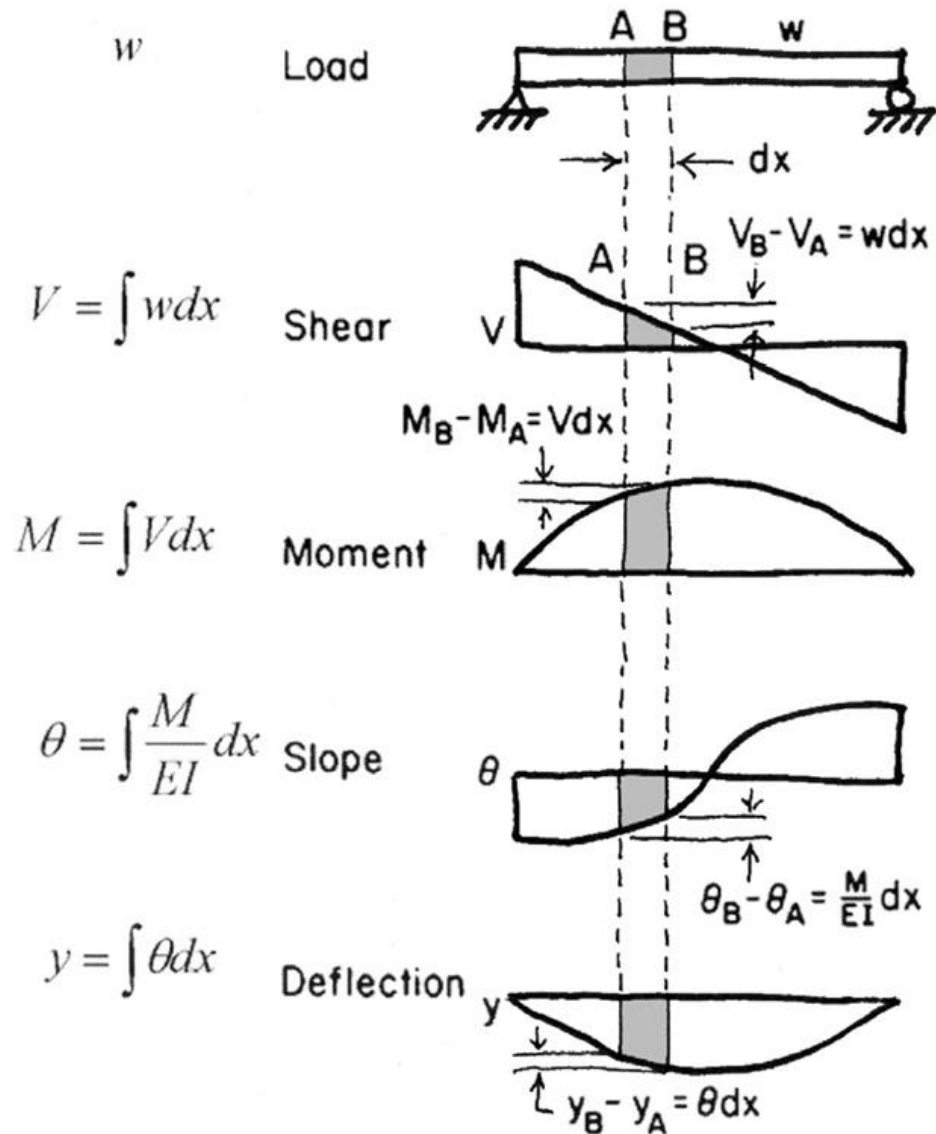

Recap of the week

1. Equilibrium Method - example

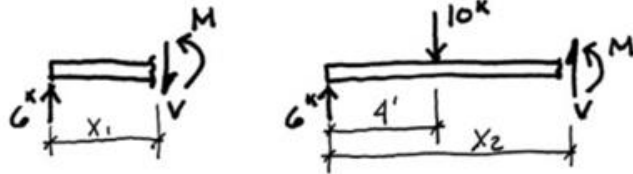

$-w$



$$V = \int w dx$$

$$V = -wx + C$$

$$V = -wx + \frac{wl}{2}$$



$$M = \int V dx$$

$$M = -\frac{w}{2}x^2 + \frac{wl}{2}x + C$$

$$M = -\frac{w}{2}x^2 + \frac{wl}{2}x$$



Methods to Determine Values of Shear and Moment

1. Equilibrium Method

- Select a point along the beam
- Cut a section and draw the FBD
- Solve for the internal shear and moment forces at the section

2. Integration of Equations

- Write the equation of the load function
- Integrate load equation to get shear equation
- Solve integration constant (use end reaction)
- Integrate shear equation to get moment equation
- Solve integration constant (use point with zero moment, e.g. end point)

3. Semi-graphical Method

- Draw load diagram and solve end reactions with equilibrium equations.
- Start at left and construct the shear diagram using point loads and areas on load diagram
- Calculate areas of shear diagram to find change in value on moment diagram
- Find points of zero moment to begin moment diagram, e.g. end points

4. Superposition of Equations

- Break the loading into standard cases
- Use given equations to solve shear and moment for each case
- Add the cases to get combined values of original loading

Recap of the week

3. Shear and Moment by **Semi-graphical Method** – diagram relationships

By recognizing the diagrammatic relationships between curves and their derivatives and integrals, shear and moment diagrams can be constructed based on areas and slopes of those curves.

Moving from Upper to Lower Diagrams:

- The area between any two points on the upper diagram is equal to the change in value between same points on the lower diagram.
- The degree of the curve increases by one for each diagram.
- The value on the upper diagram is equal to the slope of the lower diagram.
- Where the upper diagram crosses 0 on the axis, the lower diagram is at a maximum or minimum.
- Points of inflection or “contraflexure” (between + and – curvature) on the elastic curve (deflected shape) are points of zero moment.

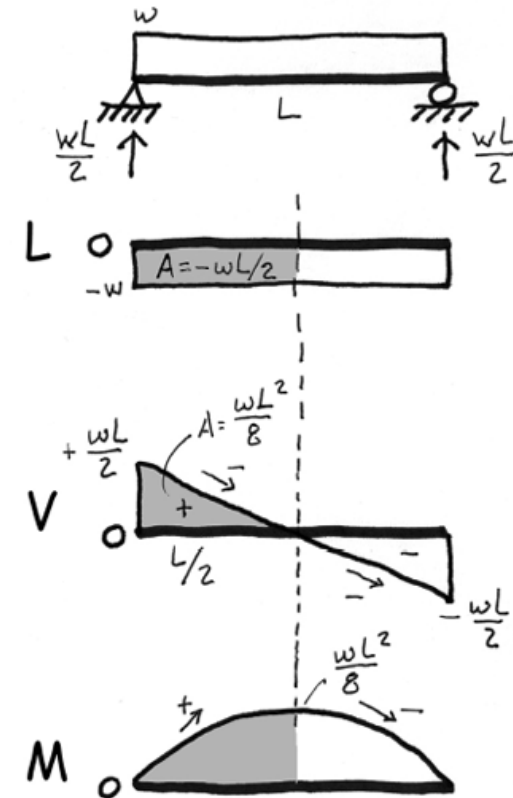

Recap of the week

3. Semi-graphical Method

Procedure:

1. Find end reactions
2. Start at left end of V-Diagram and “apply” load from left to right
3. Calculate areas of V-Diagram
4. Find max. and min. values on M-Diagram using V-Diagram areas between axis crossings.
5. Check slope and + or - values

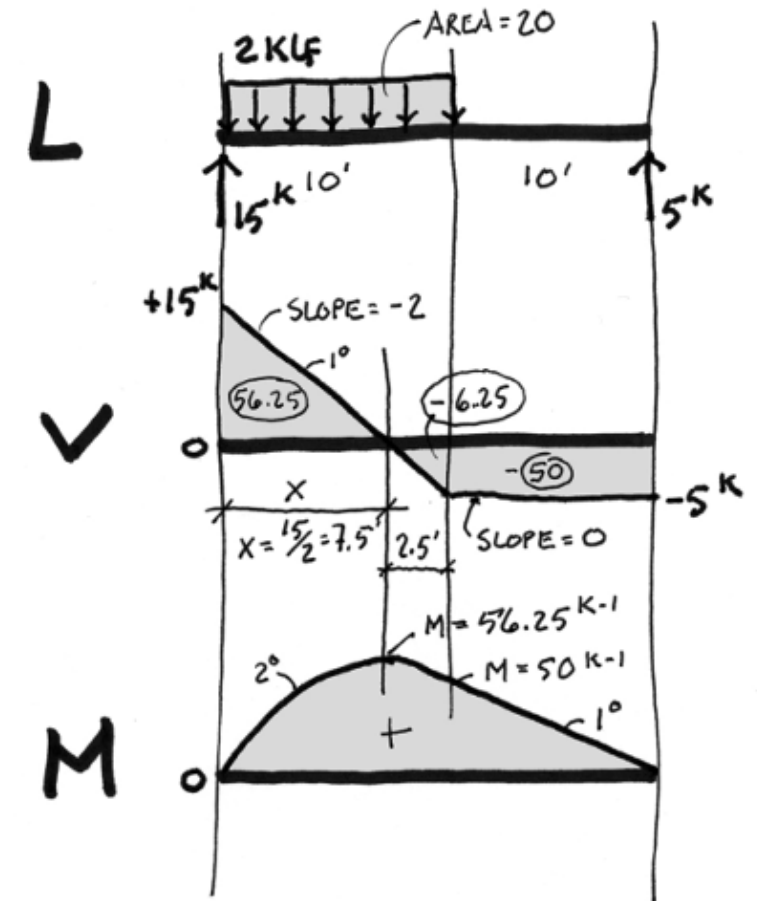

Recap of the week

4. Semi-graphical Method - Superposition

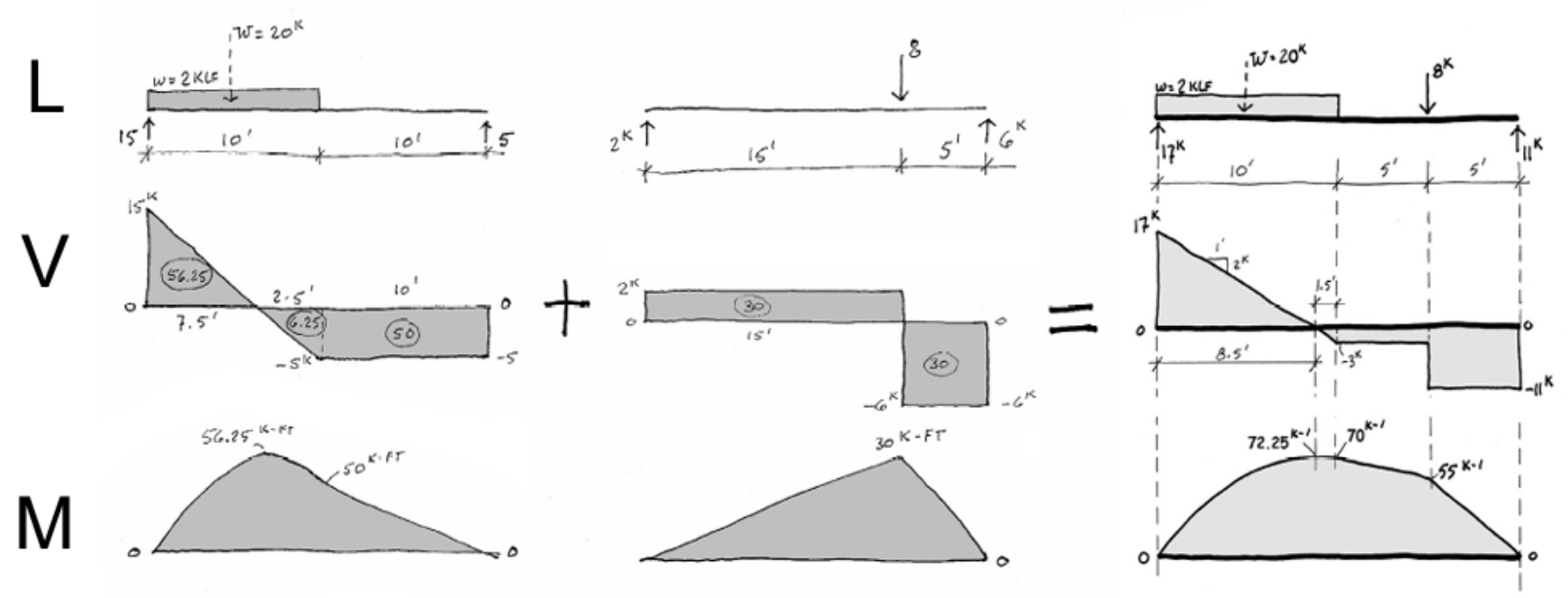

Provide the solution for the assignment – HW12

- Problem:

14. Shear and Moment Diagrams

Calculate end reactions and construct the shear & moment diagrams for the loading shown.

DATASET: 1 -2- -3-

Total Span L	34 FT
Length A	14 FT
Length B	26 FT
Uniform Load on Length A (w)	310 PLF
Point Load (P)	530 LBS

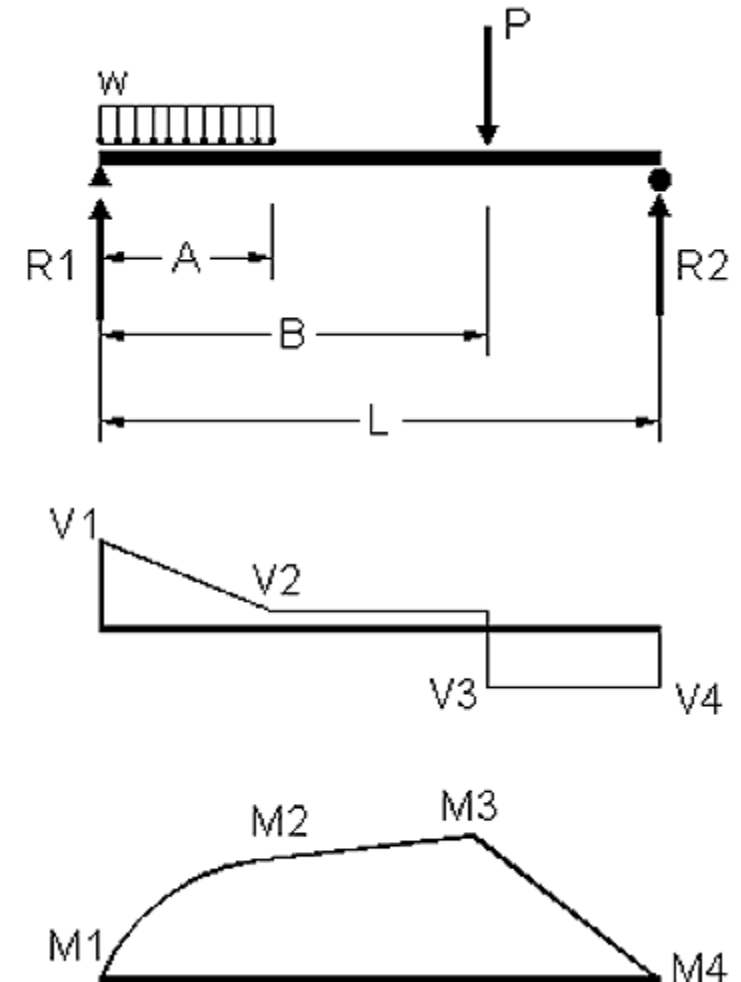

Provide the solution for the assignment – HW12

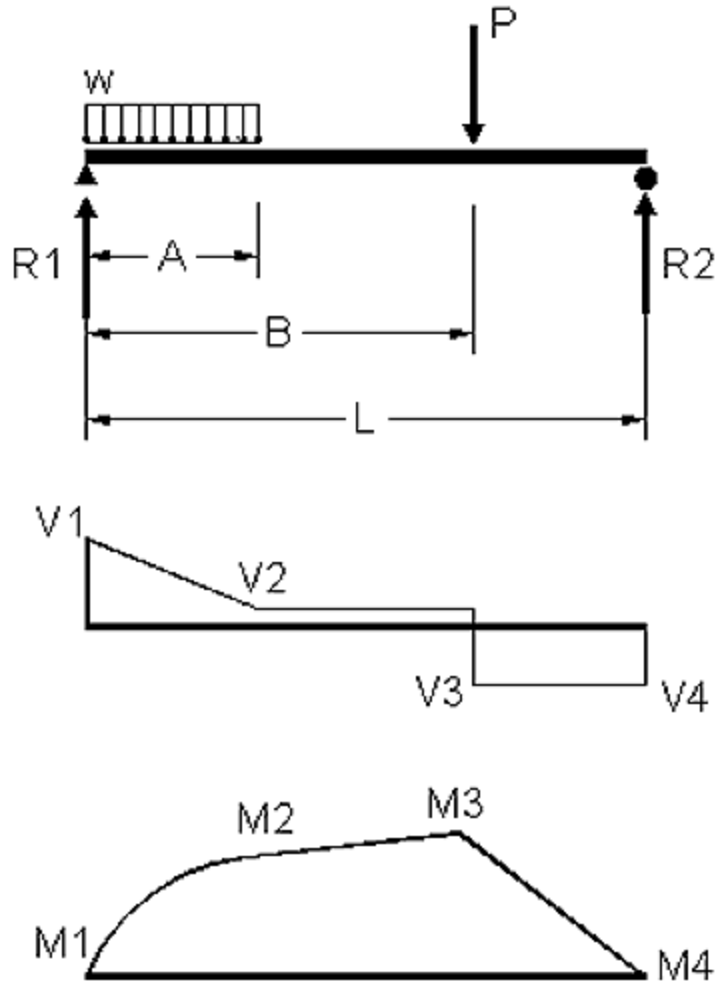

#	Question	Your Response
1	Left Reaction (R1) (+ is upward; - is downward)	<input type="text"/> LBS
2	Right Reaction (R2) (+ is upward; - is downward)	<input type="text"/> LBS
3	Peak Shear value at R1 (V1) (use + or - sign)	<input type="text"/> LBS
4	Moment value at R1 (M1)	<input type="text"/> FT-LBS
5	Shear value at A distance from R1 (V2) (use + or - sign)	<input type="text"/> LBS
6	Moment value at A dist. from R1 (M2 tension on bottom is +)	<input type="text"/> FT-LBS
7	Peak Shear value at B distance from R1 (V3) (use + or - sign)	<input type="text"/> LBS
8	Moment value at B dist. from R1 (M3 tension on bottom is +)	<input type="text"/> FT-LBS
9	Peak Shear value at R2 (V4) (use + or - sign)	<input type="text"/> LBS
10	Moment value at R2 (M4)	<input type="text"/> FT-LBS
11	Maximum Moment (tension on bottom is +)	<input type="text"/> FT-LBS
12	Distance from Left to Max. Moment in (decimal)	<input type="text"/> FT

Provide the solution for the assignment – HW12

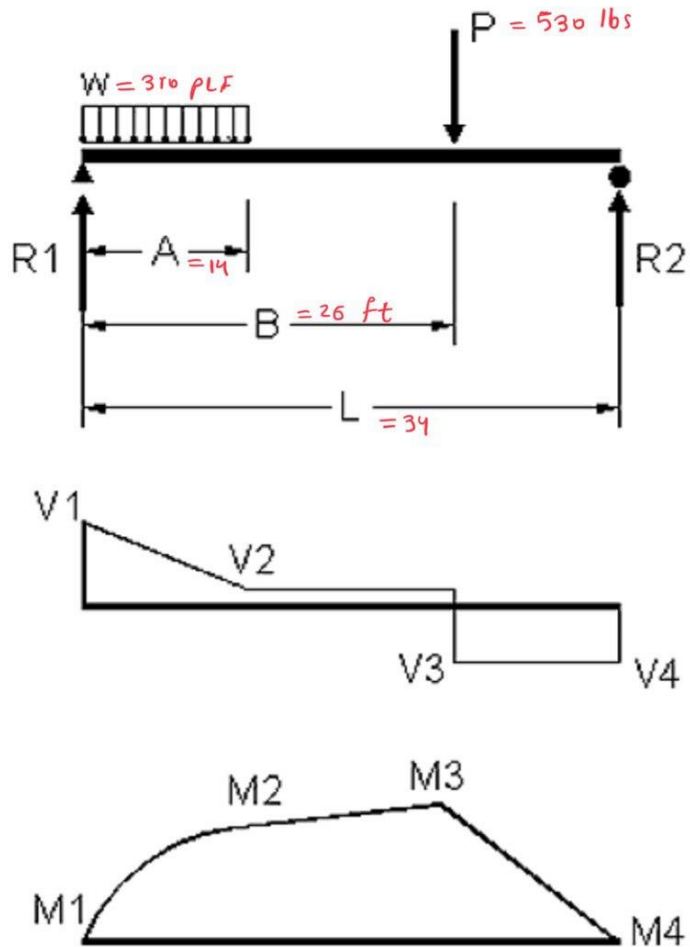

5. SIMPLE BEAM—UNIFORM LOAD PARTIALLY DISTRIBUTED AT ONE END

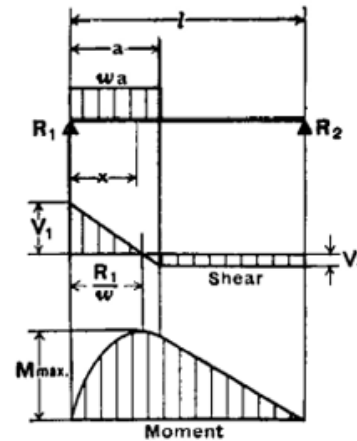

$$R_1 = V_1 \text{ max.} \dots \dots \dots = \frac{wa}{2l} (2l - a)$$

$$R_2 = V_2 \dots \dots \dots = \frac{wa^2}{2l}$$

$$V_x \text{ (when } x < a) \dots \dots \dots = R_1 - wx$$

$$M \text{ max. (at } x = \frac{R_1}{w}) \dots \dots \dots = \frac{R_1^2}{2w}$$

$$M_x \text{ (when } x < a) \dots \dots \dots = R_1x - \frac{wx^2}{2}$$

$$M_x \text{ (when } x > a) \dots \dots \dots = R_2(l - x)$$

$$\Delta x \text{ (when } x < a) \dots \dots \dots = \frac{wx}{24EI} (a^2(2l-a)^2 - 2ax^2(2l-a) + lx^3)$$

$$\Delta x \text{ (when } x > a) \dots \dots \dots = \frac{wa^2(l-x)}{24EI} (4xl - 2x^2 - a^2)$$

8. SIMPLE BEAM—CONCENTRATED LOAD AT ANY POINT

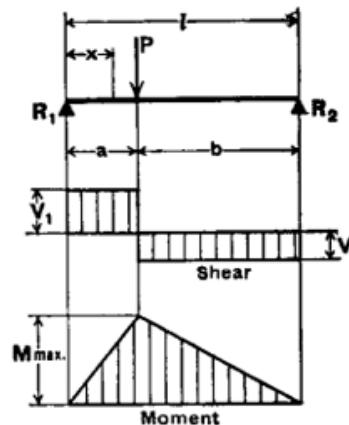

$$\text{Total Equiv. Uniform Load} \dots \dots \dots = \frac{8 Pab}{l^2}$$

$$R_1 = V_1 \text{ (max. when } a < b) \dots \dots \dots = \frac{Pb}{l}$$

$$R_2 = V_2 \text{ (max. when } a > b) \dots \dots \dots = \frac{Pa}{l}$$

$$M \text{ max. (at point of load) } \dots \dots \dots = \frac{Pab}{l}$$

$$M_x \text{ (when } x < a) \dots \dots \dots = \frac{Pbx}{l}$$

$$\Delta \text{ max. (at } x = \sqrt{\frac{a(a+2b)}{3}} \text{ when } a > b) \dots \dots \dots = \frac{Pab(a+2b)\sqrt{3a(a+2b)}}{27EI}$$

$$\Delta a \text{ (at point of load) } \dots \dots \dots = \frac{Pa^2b^2}{3EI}$$

$$\Delta x \text{ (when } x < a) \dots \dots \dots = \frac{Pbx}{6EI} (l^2 - b^2 - x^2)$$

Provide the solution for the assignment – HW12

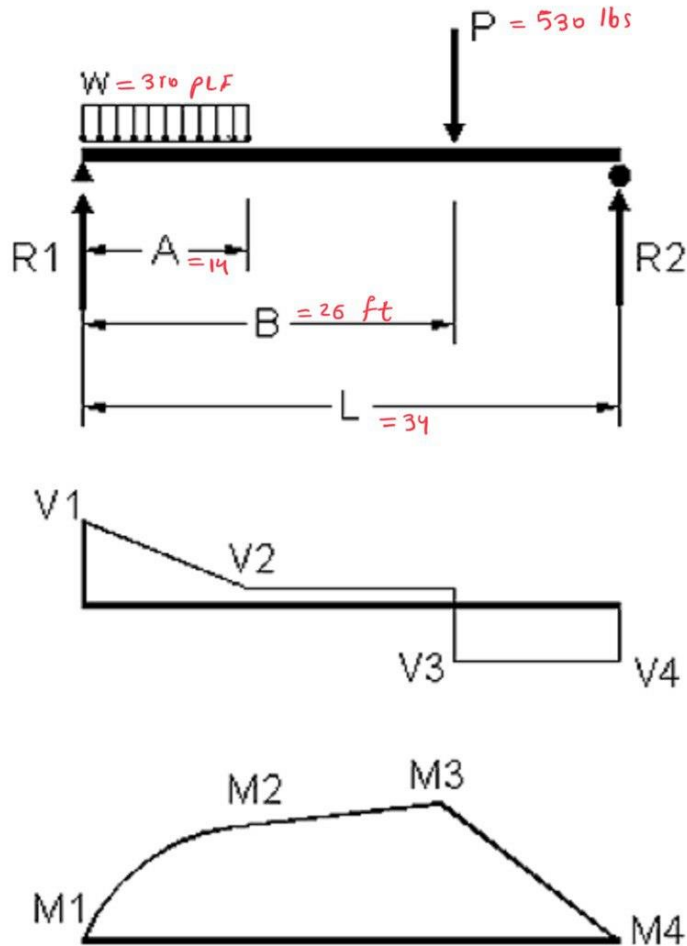

uniform load:

$$R_{1u} = \frac{wa}{2l} (2l - a) = \frac{(310)(14)}{2(34)} (2(34) - 14) = 3446.47 \text{ lbs}$$

concentrated load:

$$R_{1p} = \frac{pb}{l} = \frac{(530)(34 - 26)}{34} = 124.70$$

$$R_1 = R_{1u} + R_{1p} = 3446.47 + 124.70 = \boxed{3571.17} \text{ lbs} \quad \text{Q1}$$

$$R_{2u} = \frac{wa^2}{2l} = \frac{(310)(14)^2}{2(34)} = 893.53$$

$$R_{2p} = \frac{pa}{l} = \frac{(530)(26)}{34} = 405.29$$

$$R_2 = R_{2u} + R_{2p} = 893.53 + 405.29 = \boxed{1298.82} \text{ lbs} \quad \text{Q2}$$

Provide the solution for the assignment – HW12

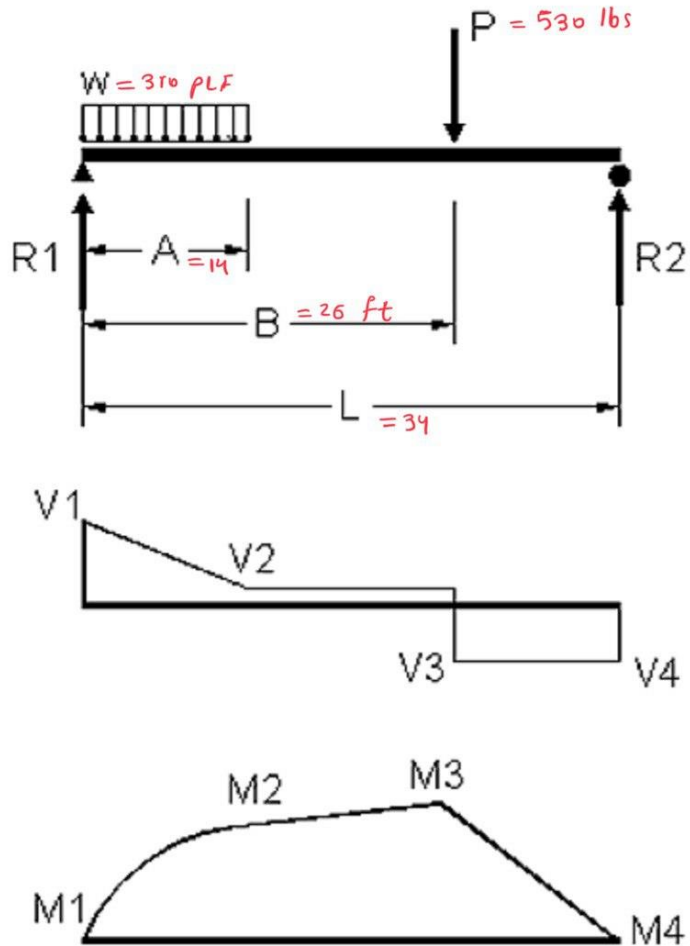

peak shear value at R_1 (V_1) V1

uniform load:

$$V_u = R_1 - wu$$

$$V_1: u = 0 \rightarrow V_1 = R_1 = 3571.17$$

Q3

shear value at the distance $A = 14$: (V_2) V2

$$V_u = R_1 - wu = 3571.17 - (310)(14) = \underline{-768.83} \text{ lbs}$$

Q5

Moment value at $R_1 = 0$

Q4

Provide the solution for the assignment – HW12

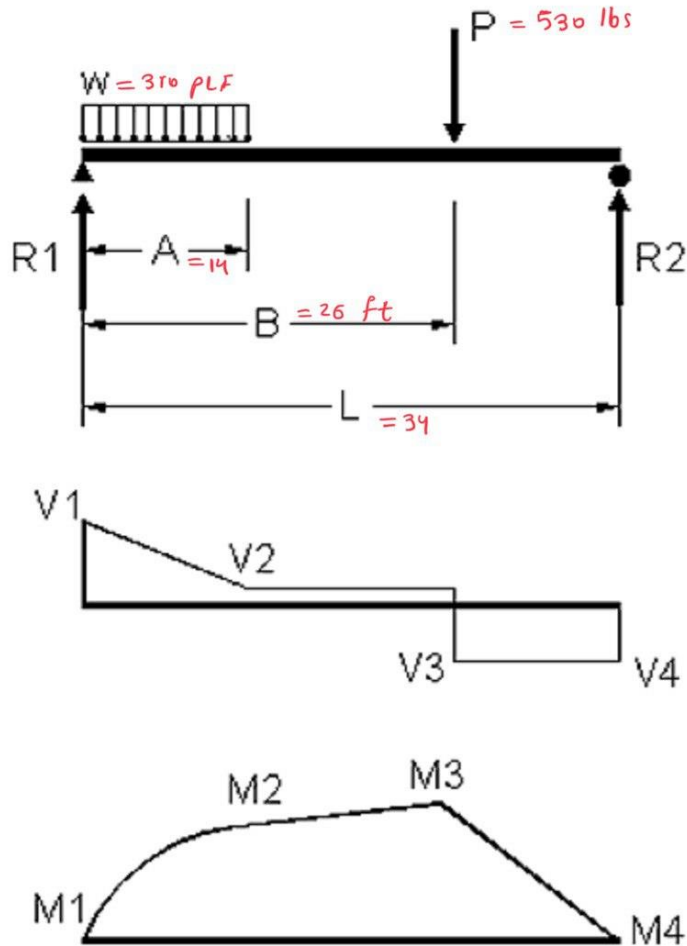

moment value at $A = 14$: M2

uniform load

$$M_u \text{ (when } u > a) = R_{2u}(1-u) = 893.53 (34-14) = 17870.6 \text{ ft-lbs}$$

or

$$M_u \text{ (when } u < a) = R_{1u}u - \frac{Wu^2}{2} = 3446.47(14) - \frac{310(14)^2}{2} = 17870.58$$

concentrated load

$$M_u \text{ (when } u < a) = \frac{pbu}{L} = \frac{(530)(34-26)(14)}{34} = 1745.88 \text{ ft-lbs}$$

At $A = 14$ $M_u = M_{uu} + M_{up} = \frac{17870.6 + 1745.88}{1} = \underline{19616.48} \text{ ft-lbs}$

Q6

Provide the solution for the assignment – HW12

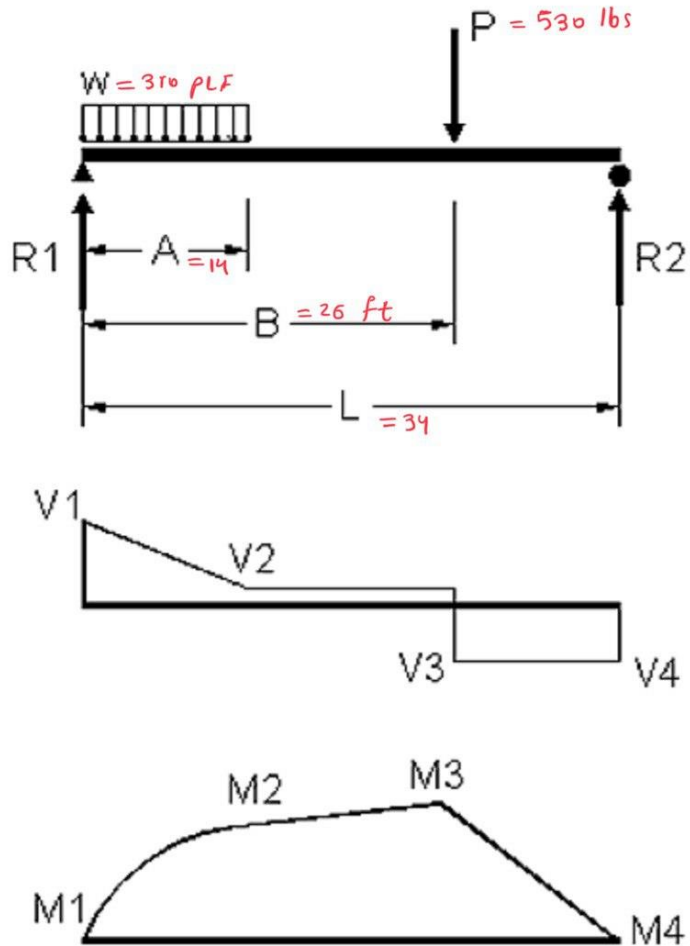

At $x = 26$: Shear V3

point load:

$$\begin{cases} V_u = V_2 = \frac{-wa^2}{2L} = \frac{-310(14)^2}{2(34)} = -893.53 \text{ lbs} \\ V_p = \frac{-Pa}{L} = \frac{-(530)(26)}{34} = -443.529 \text{ lbs} \end{cases}$$

$$V_3 = V_u + V_p = -893.53 - 443.53 = \boxed{-1337.0} \text{ lbs} \quad \text{Q7}$$

There is another way!

Note =

$$V_3 = V_2 - P$$

$$V_3 = -768.83 - 530 = -1298.83$$

Provide the solution for the assignment – HW12

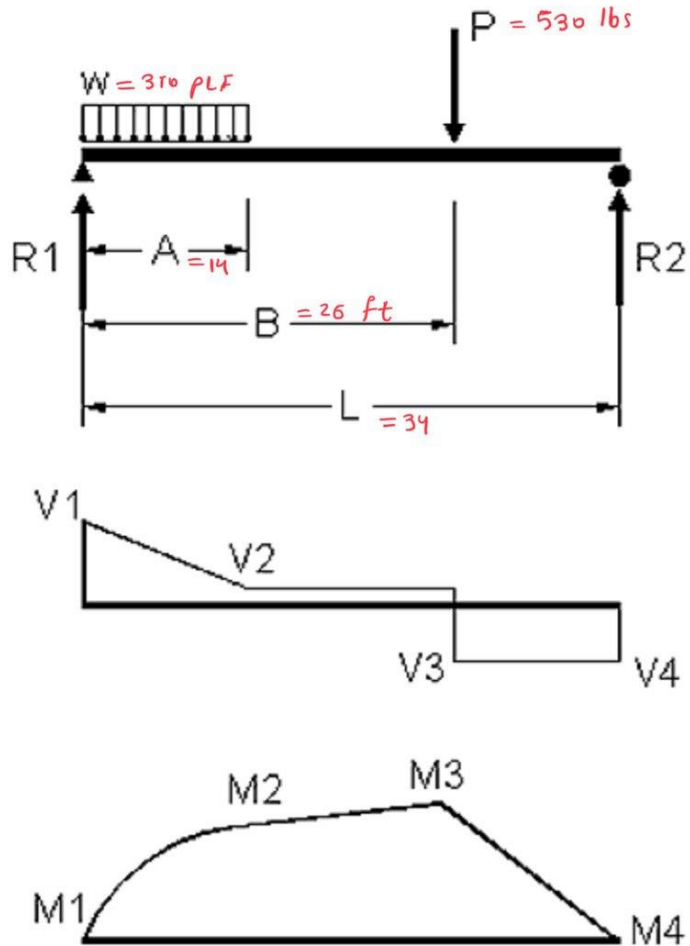

At $x = 26$: moment

M3

$$M_u \text{ (when } x > a) = R_{2u}(L-x) = 893.53(34-26) = 7148.29 \text{ Ft-lbs}$$

$$M_p \text{ (at point of load)} = \frac{pab}{L} = \frac{(530)(26)(34-26)}{34} = 3242.35 \text{ Ft-lbs}$$

$$M_3 = M_u + M_p = 7148.29 + 3242.35 = 10390.59 \text{ Ft-lbs}$$

Q8

Provide the solution for the assignment – HW12

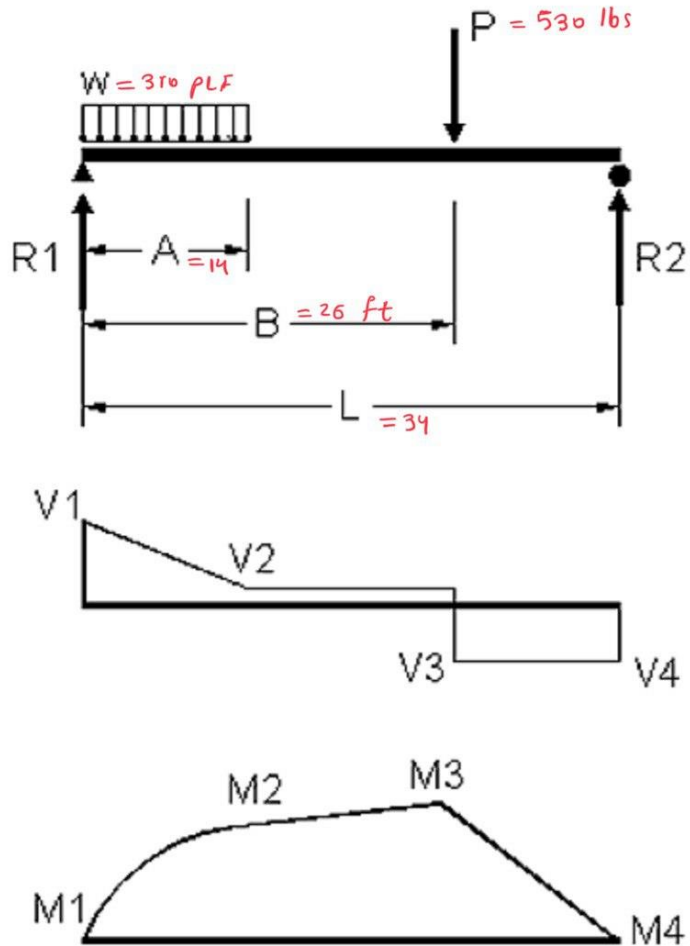

peak shear value at $R_2 (V_4)$: V_4

$$= -R_2 = -1298.82$$

Q9

moment value at $R_2 (M_u)$: $u = L = 34$

$$\int M_u = R_2 (L - u) = 0 \rightarrow M = 0$$

M4

$$M_p = 0$$

Q10

Provide the solution for the assignment – HW12

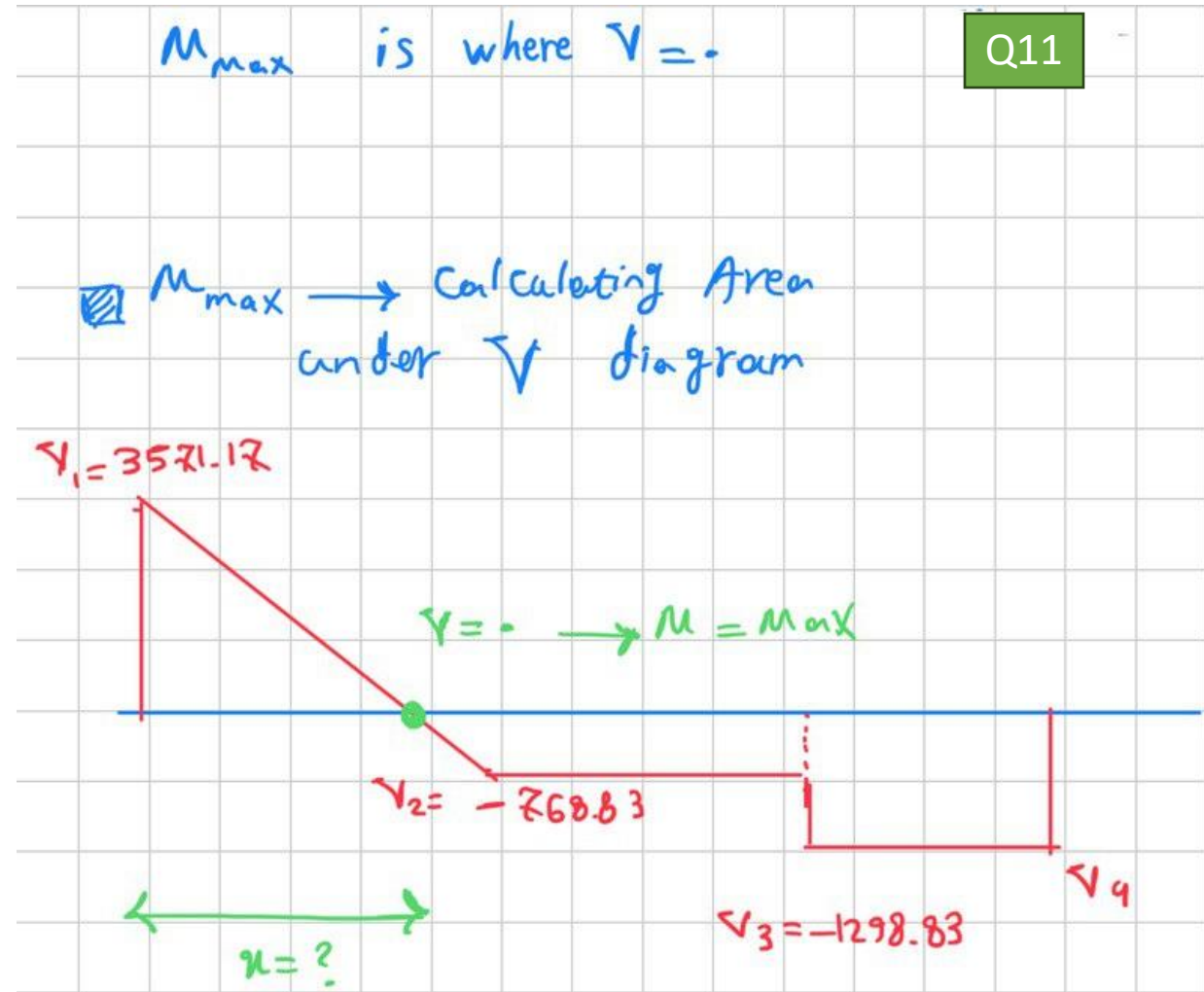
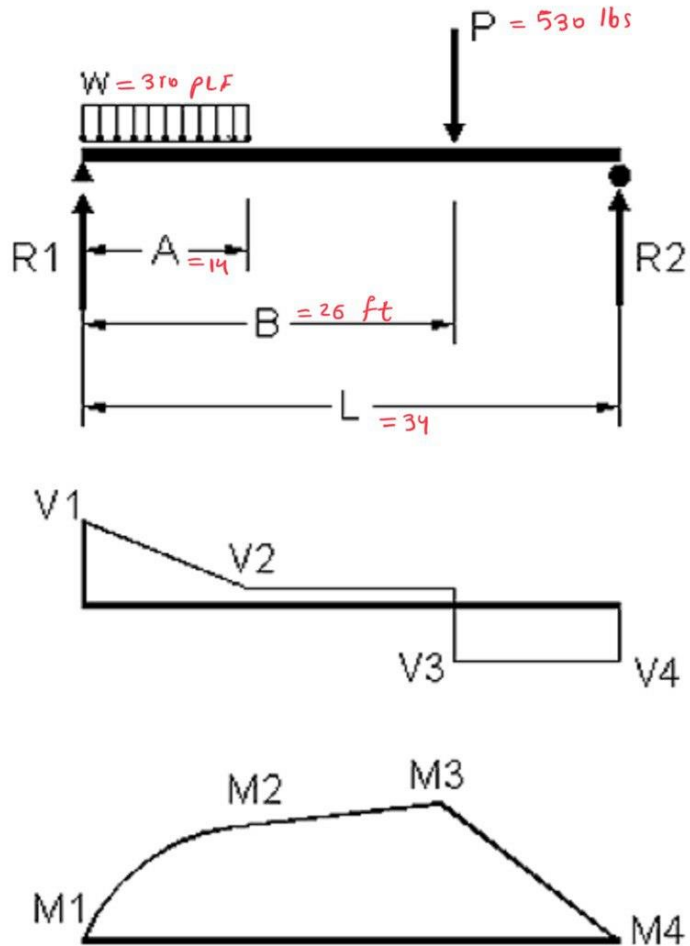

Provide the solution for the assignment – HW12

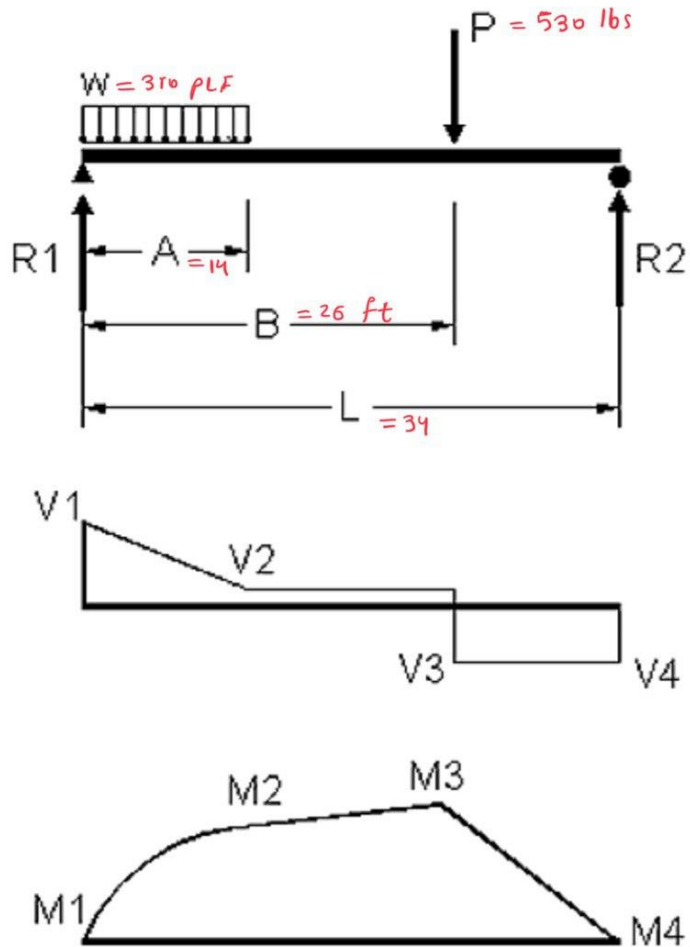

derivate moment formula and equal to zero

$$x < a$$

$$M = R_1 x - \frac{w x^2}{2} + \frac{P b x}{L}$$

$$M = 3446.47 x - \frac{310 (x)^2}{2} + \frac{530 (34 - 26) x}{34}$$

$$M = 3446.47 x - \frac{310 x^2}{2} + 124.70 x$$

$$\frac{dM}{dx} = 3446.47 - 310 x + 124.70$$

$$\rightarrow x = 11.52 \text{ ft}$$

M at $x = 11.52 \rightarrow$

$$M_{\max} = 3446.47 (11.52) - \frac{310 (11.52)^2}{2} + 124.70 (11.52)$$

$$= 39703.33 - 20570.112 + 1436.544$$

$$= 20569.762 \text{ ft}\cdot\text{lbs}$$

Q12

Q11

Lab: Moment Diagram

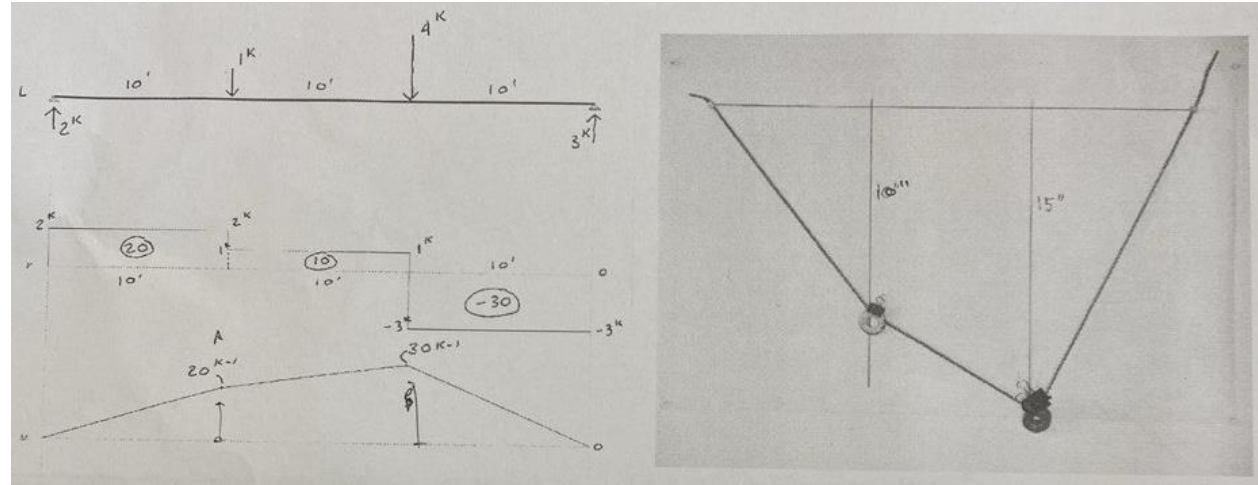

Description

This project compares a calculated moment diagram with one constructed with a weighted string.

Goals

To measure the distances to the weights on a catenary model.

To compare the scaled height of the string model with the calculate heights on the diagram.

Procedure

1. Check the shear and moment diagrams for the beam below.
2. Place the same load on the string and measure the deflection at the weights.
3. Compare the string model with the moment diagram and determine the scale factors.

Bridge Project_ Final Report

- Pay Particular attention to the Tally sheet and requirements. (We Don't want you to lose points!)
- Look at the examples provided in the course website.
- It is not finished yet! Prepare your report Properly.

PRELIMINARY REPORT (re-submit original)	40
TESTING	60
FINAL REPORT REQUIREMENTS	150

Arch314: STRUCTURES I

Thank you.

Any question?

Please feel free to ask questions.