

Arch 314

Structures I

Fall 2025 Recitation 004

Peter von Bülow
Amely Wackerbauer

Recitation 004

Welcome to session 10! (only one more after today!)

- Final Report
- Quick Recap of this week's lecture
- Homework Review (#13 Horizontal Shear)
- Lab: Shear & Bending

Feel free to ask questions anytime

Bridge

Due Date: Moved to Mon (12/1)!!

*Make sure to refer to the **scoring rubric and final report guidelines** on Structures website to see what you need to include + how GSI's will grade your paper!

FINAL REPORT REQUIREMENTS	150	
Preliminary Design Development	20	
How initial (preliminary) bridge design was developed	4	
How initial (preliminary) member sizes were chosen	4	
Why bridge design was or was not adjusted from preliminary design	4	
Why member sizes were or were not adjusted from preliminary design	4	
Discussion of how pre-analysis of initial bridge impacted the final design	4	
Revised Bridge Design Analysis	50	
Internal axial force calculations/modeling (with proper design loading indicated) (Dr. Frame acceptable)	10	
Derivation of member cross-sectional areas from axial forces	10	
Member size selection from available stock	4	
Est. weight calculation of bridge - including members, glue & fasteners	6	
Method of joints/sections calculation for at least 1 joint (@ reaction is usually easiest based on truss geometry, but could be done elsewhere)	10	
Member crushing calculations/check (show work) using $F_c = P/A$	4	
Prediction of capacity of bridge and mode of failure	6	
Illustration of Tested (Revised from Preliminary) Design	20	
Cross-section of bridge	4	
Elevation(s) of bridge	4	
Dimensions and units labeled in elevation and cross-section	4	
Member sizes labeled (with dimensions)	4	
Member stresses labeled (with units)	4	
Testing Results	30	
Weight and height of bridge	5	
Capacity of bridge	5	
Observations of testing	6	
Description of mode of failure	5	
Images of failure	5	
Following the guidelines	4	
Post-Testing Analysis	30	
Comparison of testing with predicted capacity and modes of failure	10	
Discussion of discrepancies between results	10	
Suggested improvements for future designs with reasoning discussed	10	
FINAL GRADE	250	
Up to 20 pts may be withheld for a lack of clarity or professional quality. 8.5"x11" PAPER ONLY!		

Lecture: Bending Stress in Beams (11/17) & Shear Stress in Beams (11/19)

Architecture 314
Structures I

Bending Stresses in Beams

- Elastic Bending
- Stress Equation
- Section Modulus
- Flexure Capacity Analysis
- Flexure Beam Design

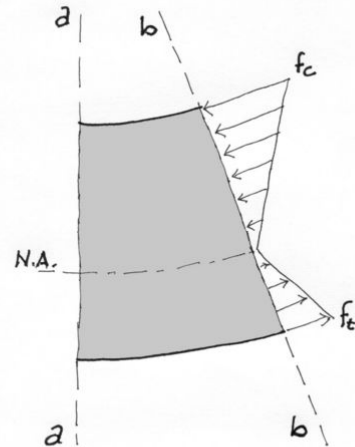

Architecture 314
Structures I

Shear Stresses in Beams

- Shear Stress
- Horizontal Shear
- Shear Profile
- Shear Design
- Shear Connections
- Principal Stress

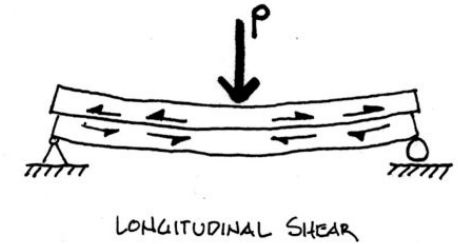
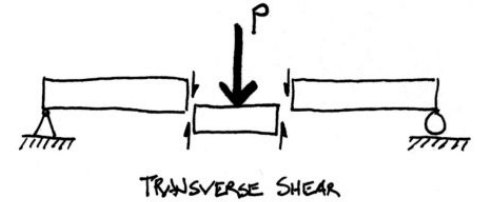

Lecture: Last Week: Shear and Bending - Pt 1 + Pt 2 (11/10 + 11/12)

Methods to Determine Values of Shear and Moment

1. Equilibrium Method

- Select a point along the beam
- Cut a section and draw the FBD
- Solve for the internal shear and moment forces at the section

2. Integration of Equations

- Write the equation of the load function
- Integrate load equation to get shear equation
- Solve integration constant (use end reaction)
- Integrate shear equation to get moment equation
- Solve integration constant (use point with zero moment, e.g. end point)

3. Semi-graphical Method

- Draw load diagram and solve end reactions with equilibrium equations.
- Start at left and construct the shear diagram using point loads and areas on load diagram
- Calculate areas of shear diagram to find change in value on moment diagram
- Find points of zero moment to begin moment diagram, e.g. end points

4. Superposition of Equations

- Break the loading into standard cases
- Use given equations to solve shear and moment for each case
- Add the cases to get combined values of original loading

1. Equilibrium Method - example

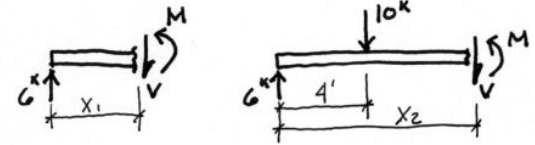

2. Shear and Moment by Integration - example

One method of solving shear and moment forces is to write the loading equation and solve the integration equations for the shear and moment. One problem using this method can be finding the constant of integration, particularly with discontinuous load functions.

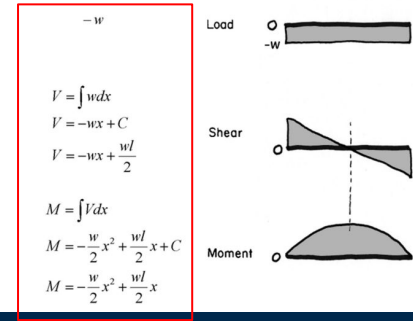

HW #13: Horizontal Shear

13. Horizontal Shear

Determine the maximum overall shear force and the horizontal shear stress at that location. Then find the horizontal shear stress at each end of the center web (top and bottom).

DATASET: 1

Section dimension A	4 IN
Section dimension B	4 IN
Section dimension C	1 IN
Section dimension D	7 IN
Section dimension E	8 IN
Section dimension F	4 IN
Beam span A	8 FT
Beam span B	11 FT
Beam load w1	24 PLF
Beam load w2	19 PLF

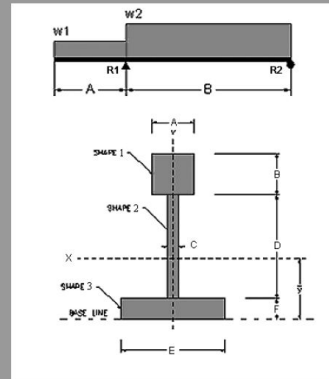

Your answer was correct.
You scored 5 points.

#	Question	Your Response	Correct Answer	Score
1	Beam reaction R1 (upward is +)	366.32 LBS	366.318 LBS	5
2	Beam reaction R2 (upward is +)	34.68 LBS	34.6818 LBS	5
3	Negative shear at R1 (use - sign)	-192 LBS	-192 LBS	5
4	Positive shear at R1	174.32 LBS	174.318 LBS	5
5	Shear at R2 (use - or + sign)	-34.68 LBS	-34.6818 LBS	5
6	Maximum shear force (absolute value)	192 LBS	192 LBS	5
7	Static Moment (Q) at top of shape 2	113.6 IN ³	113.6 IN ³	5
8	Static Moment (Q) at bottom of shape 2	124.8 IN ³	124.8 IN ³	5
9	Static Moment (Q) at the neutral axis	126.605 IN ³	126.605 IN ³	5
10	Moment of Inertia about the neutral axis	1403.78 IN ⁴	1403.78 IN ⁴	5
11	Section width at the neutral axis	1 IN	1 IN	5
12	Horizontal shear stress at the top of shape 2 for Vmax	15.54 PSI	15.5374 PSI	5
13	Horizontal shear stress at the bottom of shape 2 for Vmax	17.098 PSI	17.0693 PSI	5
14	Horizontal shear stress at the neutral axis for Vmax	17.345 PSI	17.3162 PSI	5

HW #13: Horizontal Shear

DATASET: 1	-2-	-3-
Section dimension A	4 IN	
Section dimension B	4 IN	
Section dimension C	1 IN	
Section dimension D	7 IN	
Section dimension E	8 IN	
Section dimension F	4 IN	
Beam span A	8 FT	
Beam span B	11 FT	
Beam load w1	24 PLF	
Beam load w2	19 PLF	

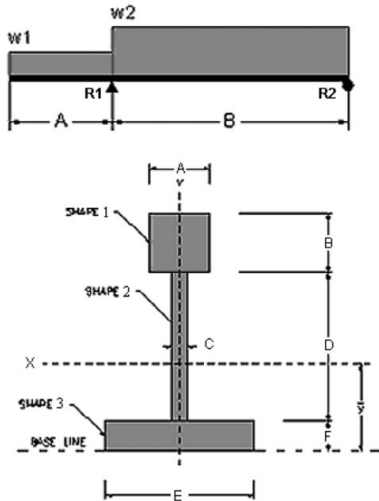

$$W_1 = w_1 \times \text{span A}$$

$$= 24 \times 8$$

$$W_1 = 192 \text{ LBS}$$

$$W_2 = w_2 \times \text{span B}$$

$$= 19 \times 11$$

$$W_2 = 209 \text{ LBS}$$

1. $\sum M_{R_2} = -W_1 \left(\frac{A}{2} + B \right) + R_1 (B) - W_2 \left(\frac{B}{2} \right)$

$$= -192 \left(\frac{8}{2} + 11 \right) + R_1 (11) - 209 \left(\frac{11}{2} \right)$$

$$= -2880 + 11R_1 - 1,149.5$$

$$-11R_1 = -4,029.5$$

$$R_1 = 366.32 \text{ LBS} \quad + = \text{upward}$$

2. $\sum M_{R_1} = -W_1 - W_2 + R_1 + R_2$

$$= -192 - 209 + 366.32 + R_2$$

$$R_2 = 34.68 \text{ LBS} \quad + = \text{upward}$$

HW #13: Horizontal Shear

DATASET: 1	-2-	-3-
Section dimension A	4 IN	
Section dimension B	4 IN	
Section dimension C	1 IN	
Section dimension D	7 IN	
Section dimension E	8 IN	
Section dimension F	4 IN	
Beam span A	8 FT	
Beam span B	11 FT	
Beam load w1	24 PLF	
Beam load w2	19 PLF	

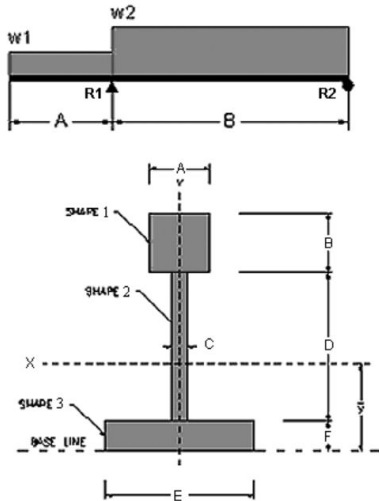

3. Negative shear at R_1

3. $V_2 = -W_1$ ← calculated earlier

$V_2 = -192 \text{ LBS}$

4. Positive shear at R_1

$V_3 = V_2 + R_1$ #1

$= -192 + 366.32$ #3

$V_3 = 174.32 \text{ LBS}$

5. Shear at R_2

$V_4 = V_3 - W_2$ #4

$= 174.32 - 209$ ← calculated earlier

$V_4 = -34.68 \text{ LBS}$

6. Maximum shear force

$V_{max} = |V_2|$ #4

$V_{max} = 192 \text{ LBS}$

HW #13: Horizontal Shear

DATASET: 1	-2-	-3-
Section dimension A	4 IN	
Section dimension B	4 IN	
Section dimension C	1 IN	
Section dimension D	7 IN	
Section dimension E	8 IN	
Section dimension F	4 IN	
Beam span A	8 FT	
Beam span B	11 FT	
Beam load w1	24 PLF	
Beam load w2	19 PLF	

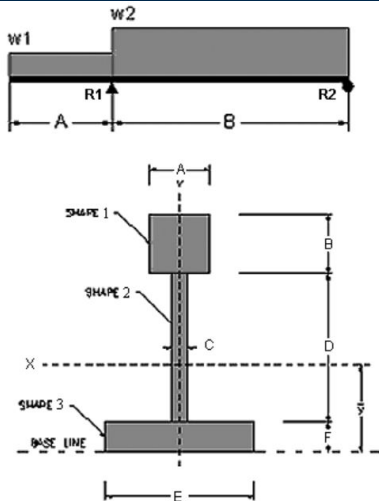

Collect some basic data

	Area ($A = b \times h$)	Distance (d)	I_2 for xx Area \times Distance (Ad)
Shape 1 	$4'' \times 4'' = 16 \text{ in}^2$	$\frac{b}{2} + D + F = 13''$	$Ad_1 = A \times d = 16 \times 13$ $= 208 \text{ in}^3$
Shape 2 	$1'' \times 7'' = 7 \text{ in}^2$	$\frac{D}{2} + F = 7.5''$	$Ad_2 = A \times d = 7 \times 7.5$ $= 52.5 \text{ in}^3$
Shape 3 	$8'' \times 4'' = 32 \text{ in}^2$	$\frac{E}{2} = 2''$	$Ad_3 = A \times d = 32 \times 2$ $= 64 \text{ in}^3$
SUM	$\Sigma A = 55$	/	$\Sigma Ad = 324.5$

$$y = \frac{\Sigma Ad}{\Sigma A}$$

$$= \frac{324.5}{55}$$

$$= 5.9''$$

^ Chart from Hw #11 - Moment of Inertia ^ same section!

HW #13: Horizontal Shear

DATASET: 1	-2-	-3-
Section dimension A	4 IN	
Section dimension B	4 IN	
Section dimension C	1 IN	
Section dimension D	7 IN	
Section dimension E	8 IN	
Section dimension F	4 IN	
Beam span A	8 FT	
Beam span B	11 FT	
Beam load w1	24 PLF	
Beam load w2	19 PLF	

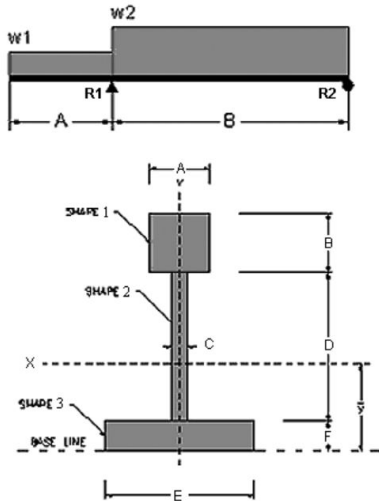

Static Moment Calculations

Diagram	Area ($A = b \times h$)	Distance (y) <i>Difference between center of shape & neutral axis</i>	$Q = \text{Area (A)} \times \text{distance (y)}$
	$4 \times 4 = 16 \text{ in}^2$	7.1 (H.W. d) $15 - 5.9 = 9.1$	$Q_{\text{top}} = 16 \times 7.1 = 113.6 \text{ in}^3$ ← Answer to #7
	$8 \times 4 = 32 \text{ in}^2$	3.9 (H.W. d) $12 - 5.9 = 3.9$	$Q_{\text{bottom}} = 32 \times 3.9 = 124.8 \text{ in}^3$ ← Answer to #8
	$A_1: 4 \times 4 = 16 \text{ in}^2$ $A_2: 5.1 \times 1 = 5.1 \text{ in}^2$	$y_1 = 15 - 5.9 = 9.1$ $y_2 = 8.45 - 5.9 = 2.55$ <i>H.W. d</i> <i>Neutral axis</i>	$Q_{\text{neutral}} = 113.6 + (5.1 \times 2.55) = 126.605 \text{ in}^3$ ← Answer to #9
		$(7 \times 4) \times 5.9 = 5.1$	$\text{center} = \frac{5.1}{2} = 2.55$ $2.55 + (7 - 5.1) + 4 = 8.45$

HW #13: Horizontal Shear

DATASET: 1	-2-	-3-
Section dimension A	4 IN	
Section dimension B	4 IN	
Section dimension C	1 IN	
Section dimension D	7 IN	
Section dimension E	8 IN	
Section dimension F	4 IN	
Beam span A	8 FT	
Beam span B	11 FT	
Beam load w1	24 PLF	
Beam load w2	19 PLF	

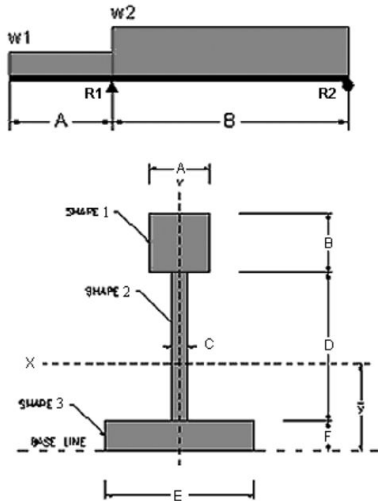

#10. Moment of inertia about the neutral axis
 Refer to hw #11 → Question #12

$$I_x = \sum I_{xx} + \sum I_2$$

$$= 95.5803 \text{ in}^4 + 1311.2 \text{ in}^4$$

$$= \boxed{1403.78 \text{ in}^4} \leftarrow \text{Answer to \#10}$$
 ∑ I_{xx} = summation of xx Moments of Inertia of all shapes (from 11)
 ∑ I₂ = summation of moments of areas x distances to centroid
 #11. Section width at neutral axis
 C = 1" - given

HW #13: Horizontal Shear

DATASET: 1		-2-	-3-
Section dimension A		4 IN	
Section dimension B		4 IN	
Section dimension C		1 IN	
Section dimension D		7 IN	
Section dimension E		8 IN	
Section dimension F		4 IN	
Beam span A		8 FT	
Beam span B		11 FT	
Beam load w1		24 PLF	
Beam load w2		19 PLF	

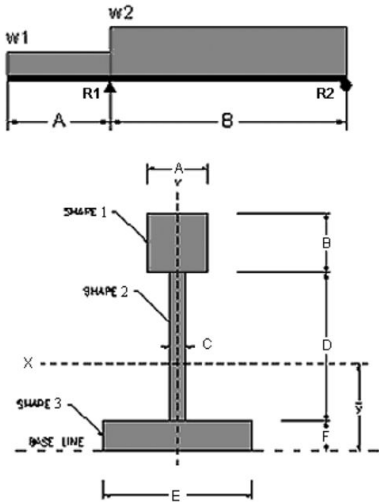

Horizontal shear stress for V_{max} , #6

$$J = \frac{V_{max} \times Q}{I \times b} = \frac{192(Q)}{\#10 \cdot 1403.78 \times 1" - C} = \frac{0.137Q}{1403.78} = J$$

12. Horizontal shear stress at top of shape 2 for V_{max}

$$Z_4 = 0.137(Q_4) \quad \#7$$

$$= 0.137(113.6)$$

$$= \boxed{15.54 \text{ PSI}}$$

13. Horizontal shear stress at bottom of shape 2 for V_{max}

$$Z_6 = 0.137(Q_6) \quad \#8$$

$$= 0.137(124.8)$$

$$= \boxed{17.098 \text{ PSI}}$$

14. Horizontal shear stress at the neutral axis for V_{max}

$$Z_0 = 0.137(Q_0) \quad \#9$$

$$= 0.137(126.605)$$

$$= \boxed{17.345 \text{ PSI}}$$

HW #13: Horizontal Shear

13. Horizontal Shear

Determine the maximum overall shear force and the horizontal shear stress at that location. Then find the horizontal shear stress at each end of the center web (top and bottom).

DATASET: 1

Section dimension A	4 IN
Section dimension B	4 IN
Section dimension C	1 IN
Section dimension D	7 IN
Section dimension E	8 IN
Section dimension F	4 IN
Beam span A	8 FT
Beam span B	11 FT
Beam load w1	24 PLF
Beam load w2	19 PLF

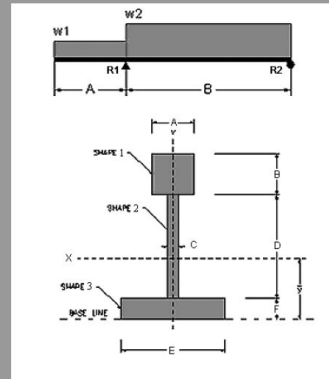

Your answer was correct.
You scored 5 points.

#	Question	Your Response	Correct Answer	Score
1	Beam reaction R1 (upward is +)	366.32 LBS	366.318 LBS	5
2	Beam reaction R2 (upward is +)	34.68 LBS	34.6818 LBS	5
3	Negative shear at R1 (use - sign)	-192 LBS	-192 LBS	5
4	Positive shear at R1	174.32 LBS	174.318 LBS	5
5	Shear at R2 (use - or + sign)	-34.68 LBS	-34.6818 LBS	5
6	Maximum shear force (absolute value)	192 LBS	192 LBS	5
7	Static Moment (Q) at top of shape 2	113.6 IN ³	113.6 IN ³	5
8	Static Moment (Q) at bottom of shape 2	124.8 IN ³	124.8 IN ³	5
9	Static Moment (Q) at the neutral axis	126.605 IN ³	126.605 IN ³	5
10	Moment of Inertia about the neutral axis	1403.78 IN ⁴	1403.78 IN ⁴	5
11	Section width at the neutral axis	1 IN	1 IN	5
12	Horizontal shear stress at the top of shape 2 for Vmax	15.54 PSI	15.5374 PSI	5
13	Horizontal shear stress at the bottom of shape 2 for Vmax	17.098 PSI	17.0693 PSI	5
14	Horizontal shear stress at the neutral axis for Vmax	17.345 PSI	17.3162 PSI	5

LAB!